

PROGRAMMA

Metodi di screening e di conferma, principi di validazione dei metodi analitici. Sensori elettrochimici, ottici e piezoelettrici, biosensori, accoppiamento del materiale biologico al trasduttore di segnale, sviluppo di sensori di affinità, immunosensori. Polimeri, stampo molecolari e aptameri come elementi di riconoscimento. Nanomateriali e sensori .

Accoppiamento tecniche cromatografiche con spettrometria di massa: GC-MS, ionizzazione a impatto elettronico e ionizzazione chimica; LC-MS, ionizzazione electrospray e APCI, analizzatori a quadrupolo, tempo di volo, trappola ionica e trappola orbitale (Orbitrap). Tecniche di frammentazione, acquisizione massa tandem (MS/MS). Pre-trattamento del campione, tecniche di estrazione e microestrazione, clean-up. Applicazioni nell'ambito delle red biotech. (2CFU)

Approcci analitici targeted e untargeted, spettrometria di massa ad alta risoluzione (HRMS), strumentazione, elaborazione dati e strumenti bioinformatici.

Matrici di sensori, naso e lingua elettronici, tipologia di trasduttori e recettori. Applicazione su analiti di interesse biotecnologico.

Casi studio derivanti da letteratura internazionale basati sulle metodologie analitiche presentate

DECISION 2002/657/CE

Classification of analytical methods

Screening methods

Only those analytical techniques, for which it can be demonstrated in a documented traceable manner that they are validated and have a **false compliant rate of < 5 %** (β -error) **at the level of interest** shall be used for screening purposes in conformity with Directive 96/23/EC. In the case of a suspected non-compliant result, this result shall be confirmed by a confirmatory method.

Confirmatory methods

Confirmatory methods for organic residues or contaminants shall provide information on the chemical structure of the analyte. Consequently methods based only on chromatographic analysis without the use of spectrometric detection are not suitable on their own for use as confirmatory methods. However, if a single technique lacks sufficient specificity, the desired specificity shall be achieved by analytical procedures consisting of suitable combinations of clean-up, chromatographic separation(s) and spectrometric detection.

Validation

Establishing documented evidence that provides a high degree of assurance that a specific process will consistently produce a product meeting its pre-determined specifications and quality attributes

“Validation of an analytical procedure is the process by which it is established, by laboratory studies, that the performance characteristics of the procedure meet the requirements for its intended use.”

There are many reasons for the need to validate analytical procedures. Among them are **regulatory requirements, good science, and quality control requirements.**

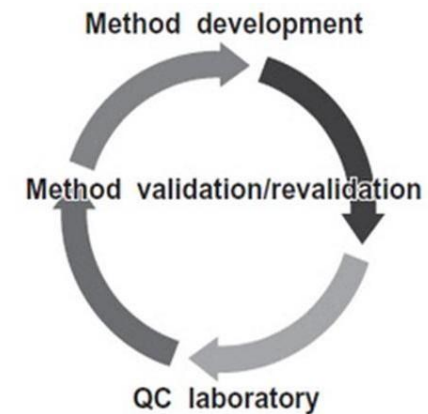

FIGURE 1 Life cycle of analytical method.

Typical validation characteristics which should be considered are:

- 1) Accuracy**
- 2) Precision**
- 3) Specificity**
- 4) Linearity**
- 5) Range**
- 6) Detection Limit**
- 7) Quantitation Limit**
- 8) Robustness/Ruggedness**
- 9) Noise**
- 10) Trueness**
- 11) Sensitivity**

What are sensors and biosensors?

"...a biosensor is a self-contained integrated device, which is capable of providing specific quantitative or semiquantitative analytical information using a biological recognition element (biochemical receptor) which is retained in direct spatial contact with a transduction element."

Technical report "Recommended definition and classification" IUPAC (Physical Chemistry and Analytical Chemistry Divisions) 2001

A **sensor** is a device able to transform a physical or chemical info (e.g. concentration of one or more compounds in a solution), into an analytical useful signal

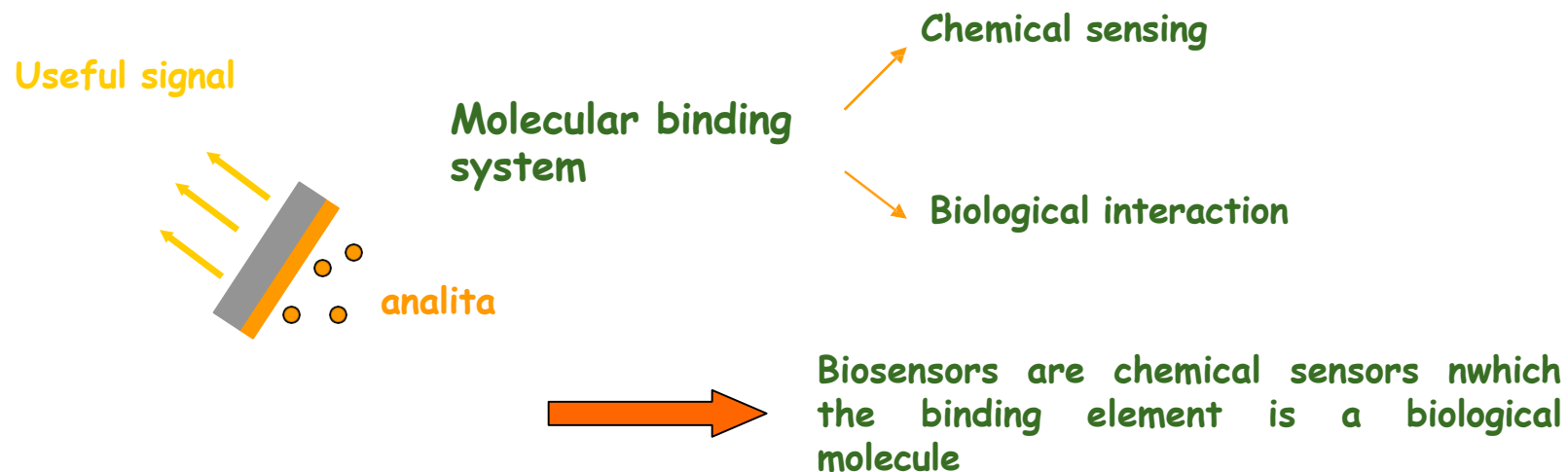

Self-testing



Numbers:

- 85% of the global market for biosensors
- 70 million tests per day worldwide
- Biosensors market 31-35 billion \$ in 2025
- 33-35 billion \$ in 2033-2035 (exp.)

The biological element translates the info of the biochemical domain (e.g. concentration) into a chemical or physical signal with a certain selectivity

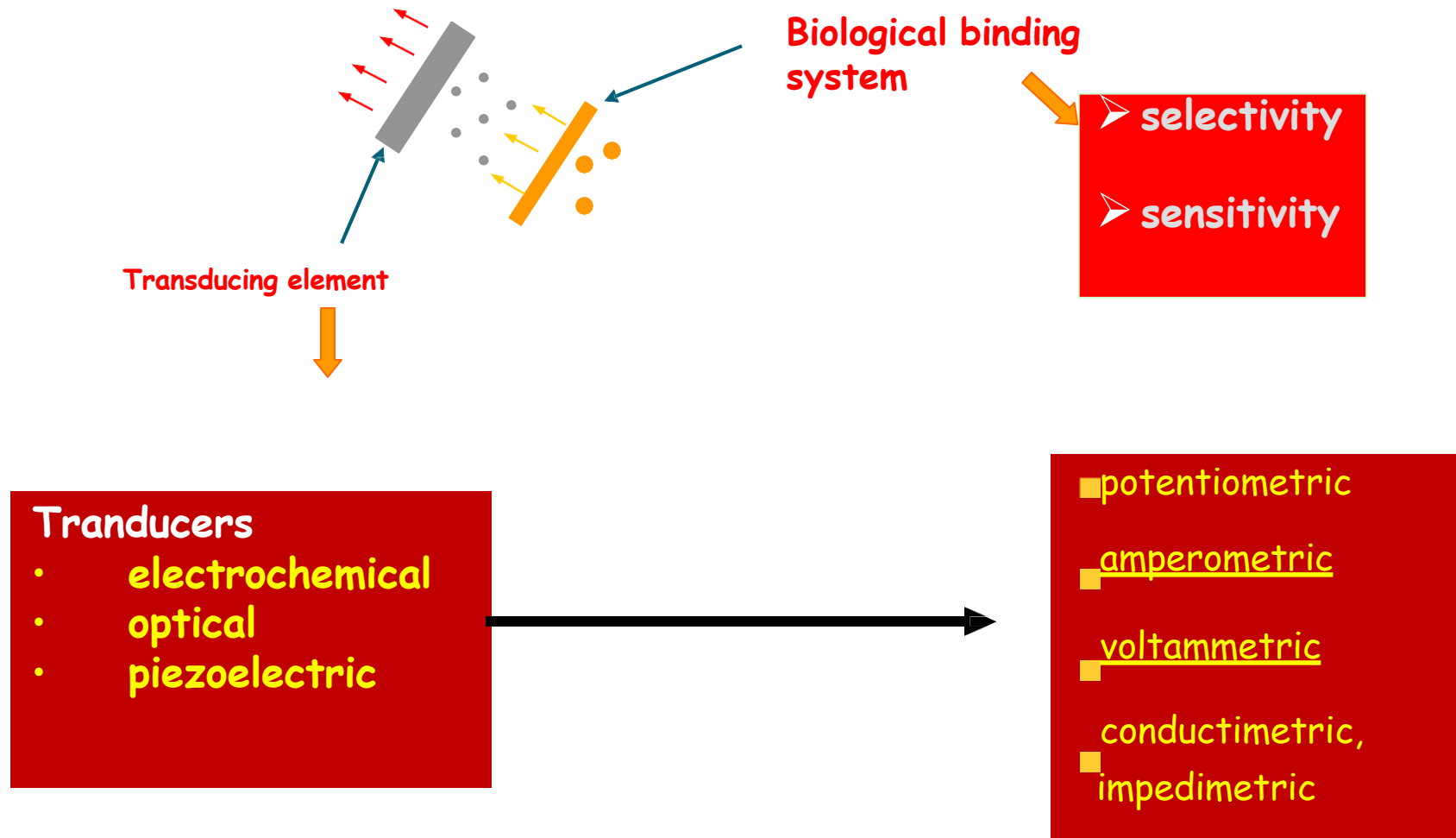

Elettrodo di riferimento+ elettrodo a pH

Il ponte salino deve essere immerso nella soluzione .

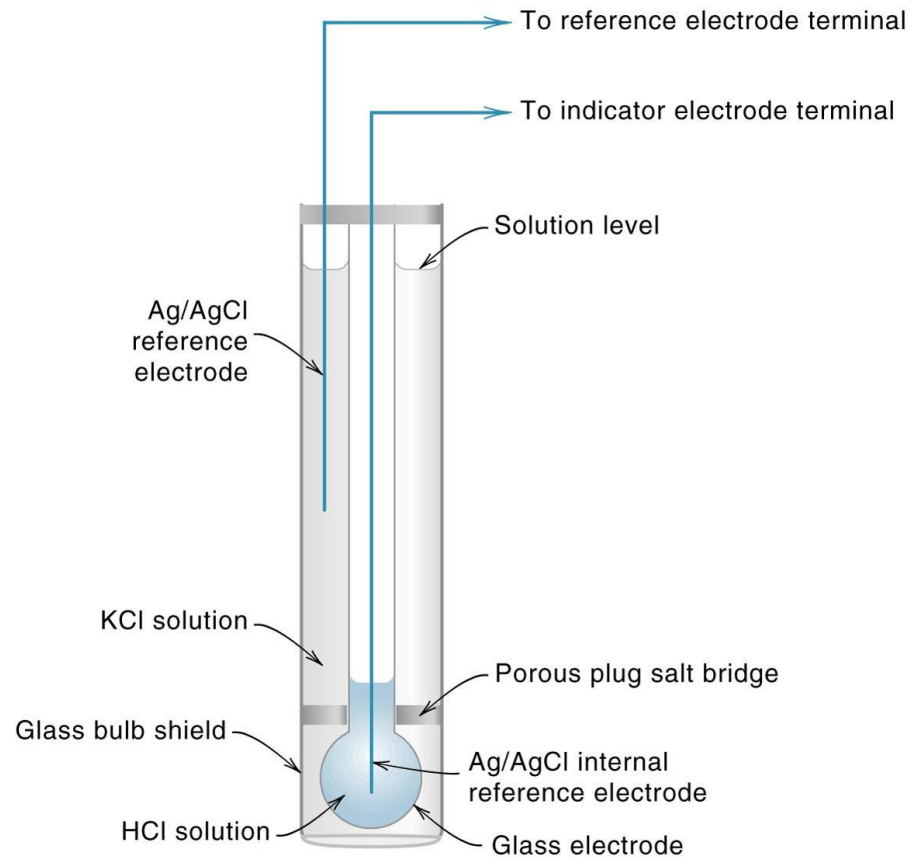

Elettrodo a pH combinato e pHmetro

Gas Ion selective electrodes

This potentiometric gas-sensors are realised using a pH glass electrode and a reference behind a gas permeable membrane (polytetrafluoroethylene, polypropylene, etc.). A very thin film of a suitable electrolyte is present between the gas permeable membrane and the surface of the pH electrode.

Hydrolysis of NH_3 or CO_2 (diffused from the sample) in the electrolyte causes a change in H^+ that is measured at the electrode.

This is related to the partial pressure of the gas in the sample solution. Immobilisation of a suitable enzyme onto the surface leads to the detection of metabolites in the 10^{-5} - 10^{-2} mol/L range.

PCO₂ ELECTRODE

- Measurement of PCO₂ in routine blood gases
- A modified pH electrode with a CO₂ permeable membrane covering the glass membrane surface
- A bicarbonate buffer separates the membranes
- Change in pH is proportional to the concentration of dissolved CO₂ in the blood

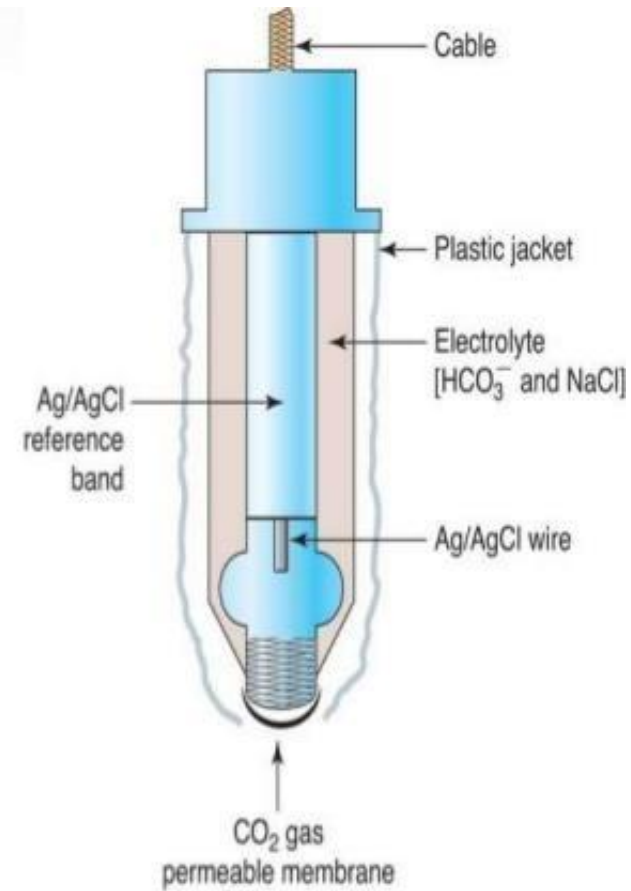

Reaction occurring in the electrolyte solution:

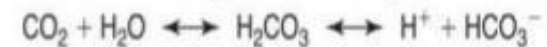

Elettrodi ioni selettivi a effetto di campo (ISFET) .

Tecnologia dei semiconduttori, il materiale ioni selettivo è simile a quello degli elettrodi tradizionali

Molto robusti ed utilizzati per le misure in campo

Fast response silicon chip sensor



Built-in reference and medical grade temperature sensor



Elettrodi ISFET a pH.

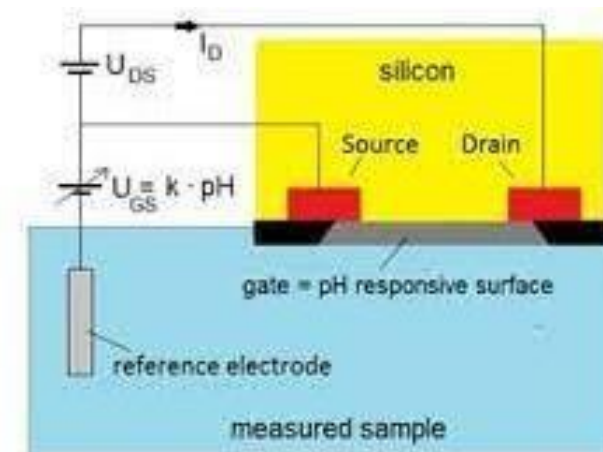
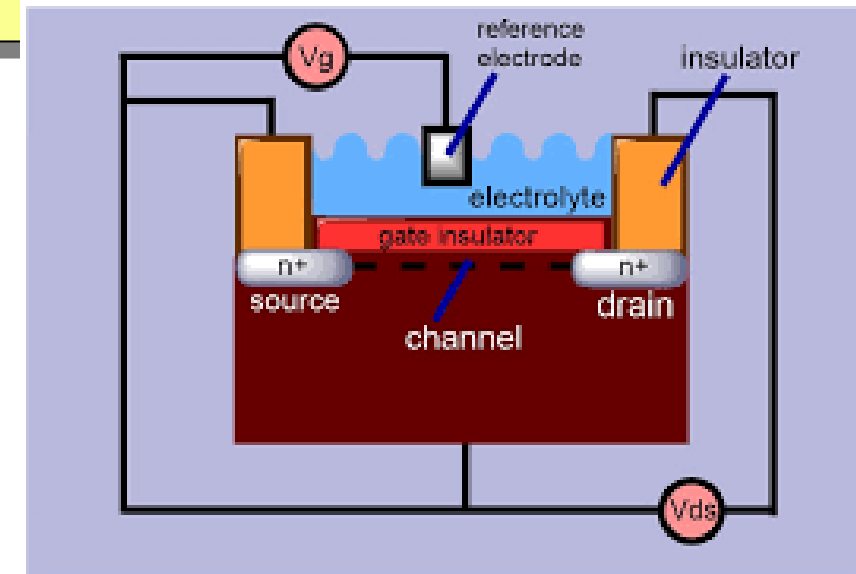

Reference electrodes

calomel

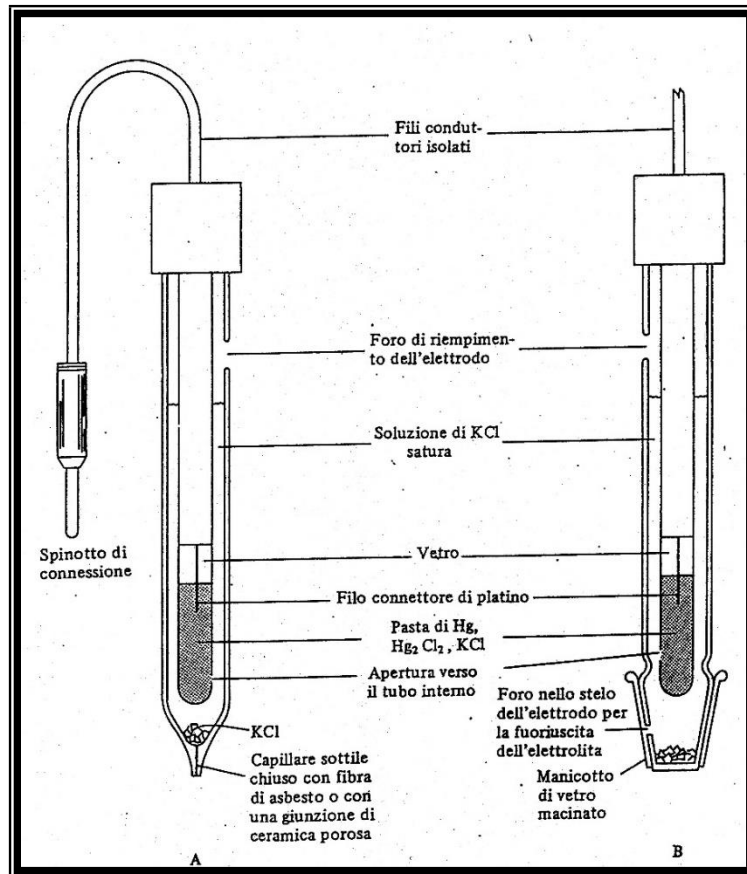

Ag/AgCl

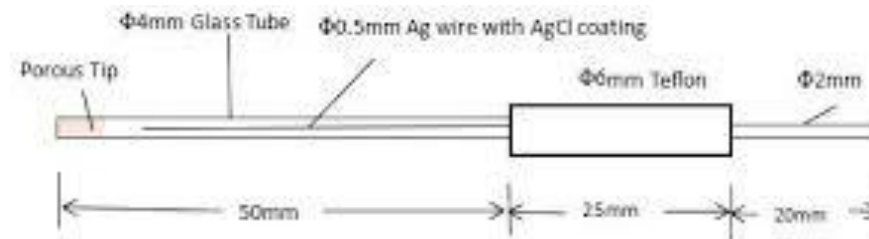

CS901 Ag/AgCl Reference Electrode

Amperometric sensors monitor the current flow when a selected fixed potential is applied at a working electrode with respect to a reference electrode. The current generated by the oxidation (or reduction) of a compound is dependent by:

- heterogeneous rate constant k
- diffusion (mass transfer) of the electroactive specie at the electrode surface
- preceding or following chemical reactions
- surface reactions (adsorption)

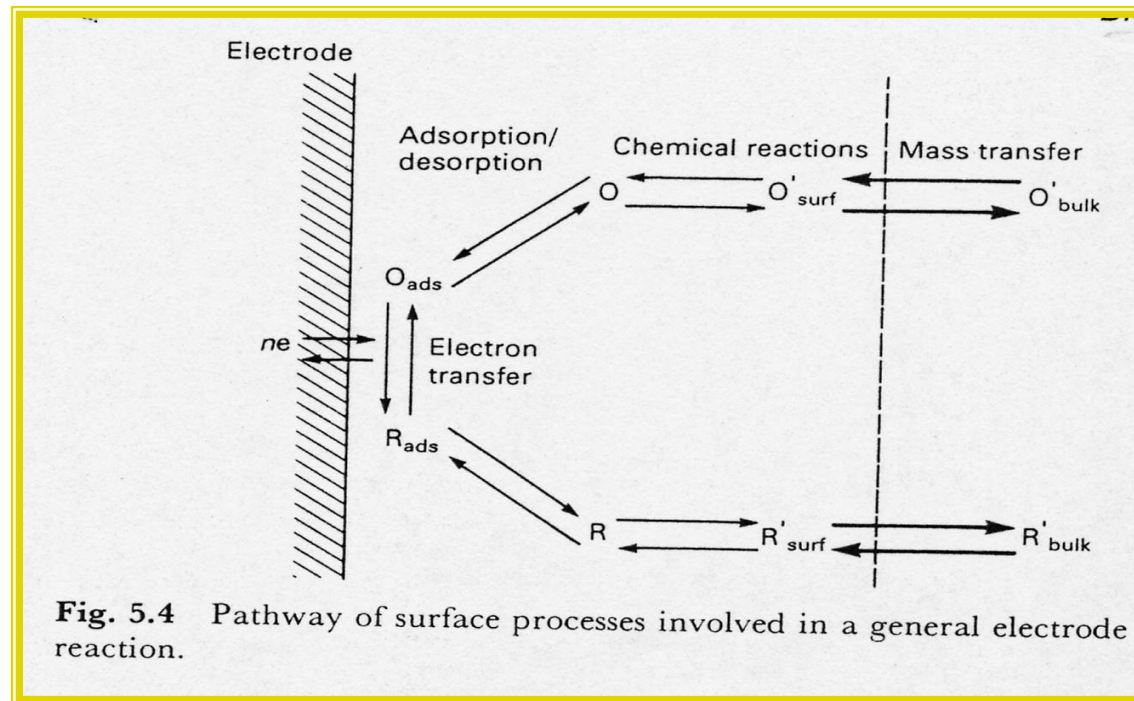

Il segnale di corrente (i) è proporzionale alla concentrazione di analita solo quando dipende esclusivamente dalla diffusione dell'analita alla superficie dell'elettrodo. Processi di migrazione di carica vengono repressi con l'uso di un **elettrolita di supporto**; quelli di convezione mediante controllo del trasporto di massa dell'analita.

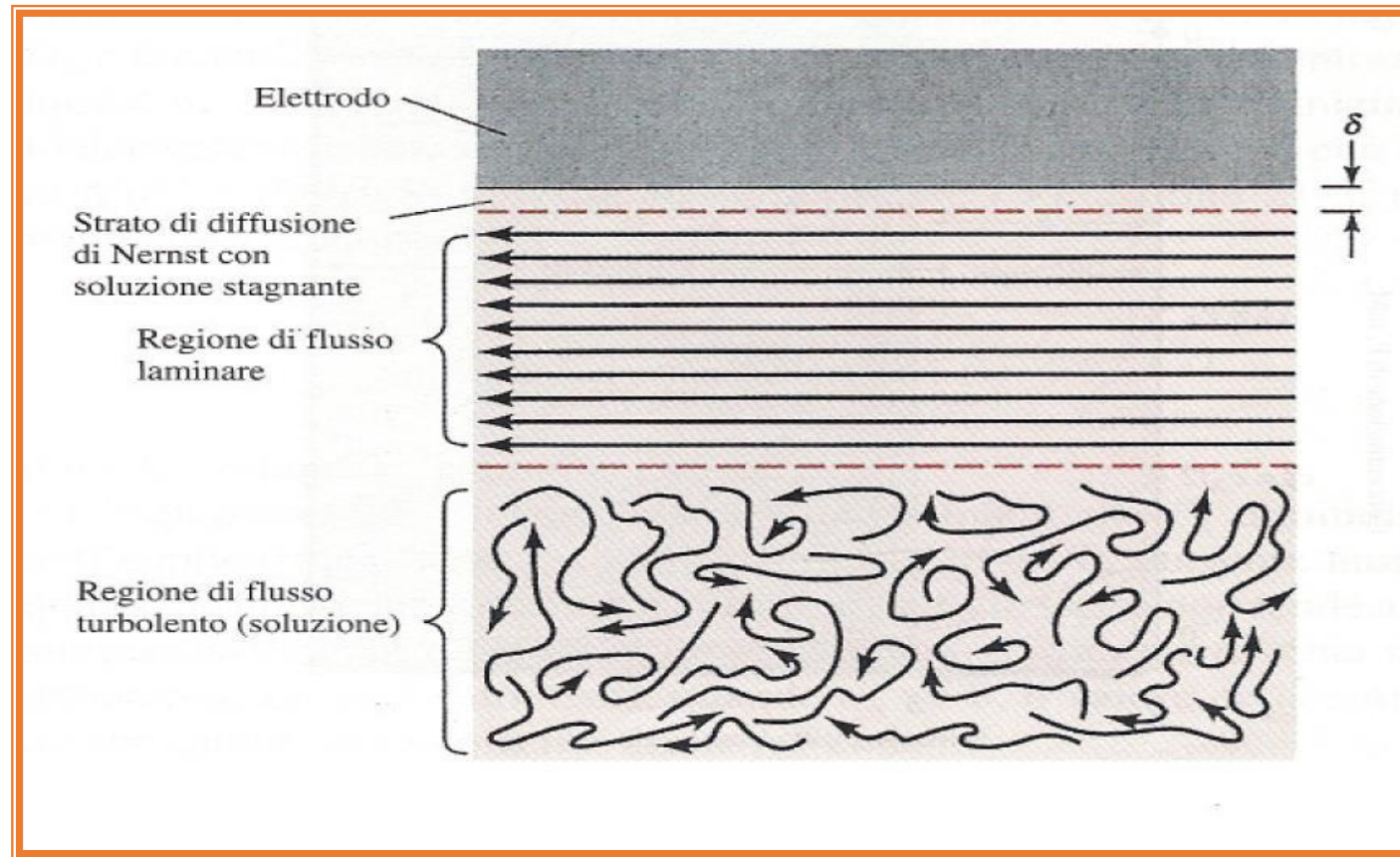

δ = spessore dello strato di diffusione

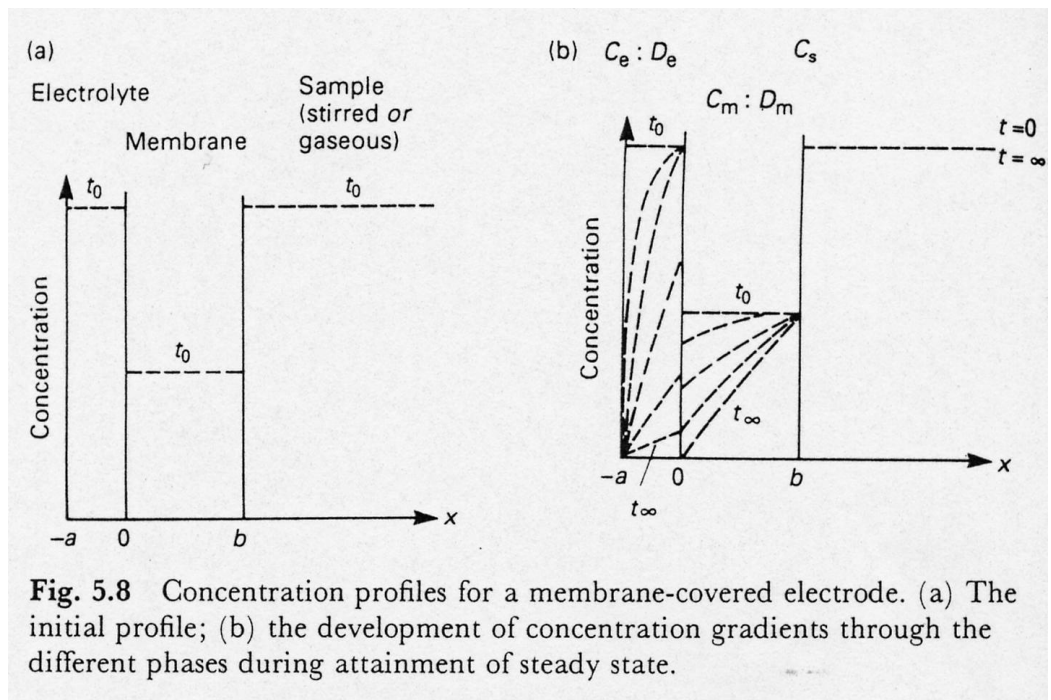
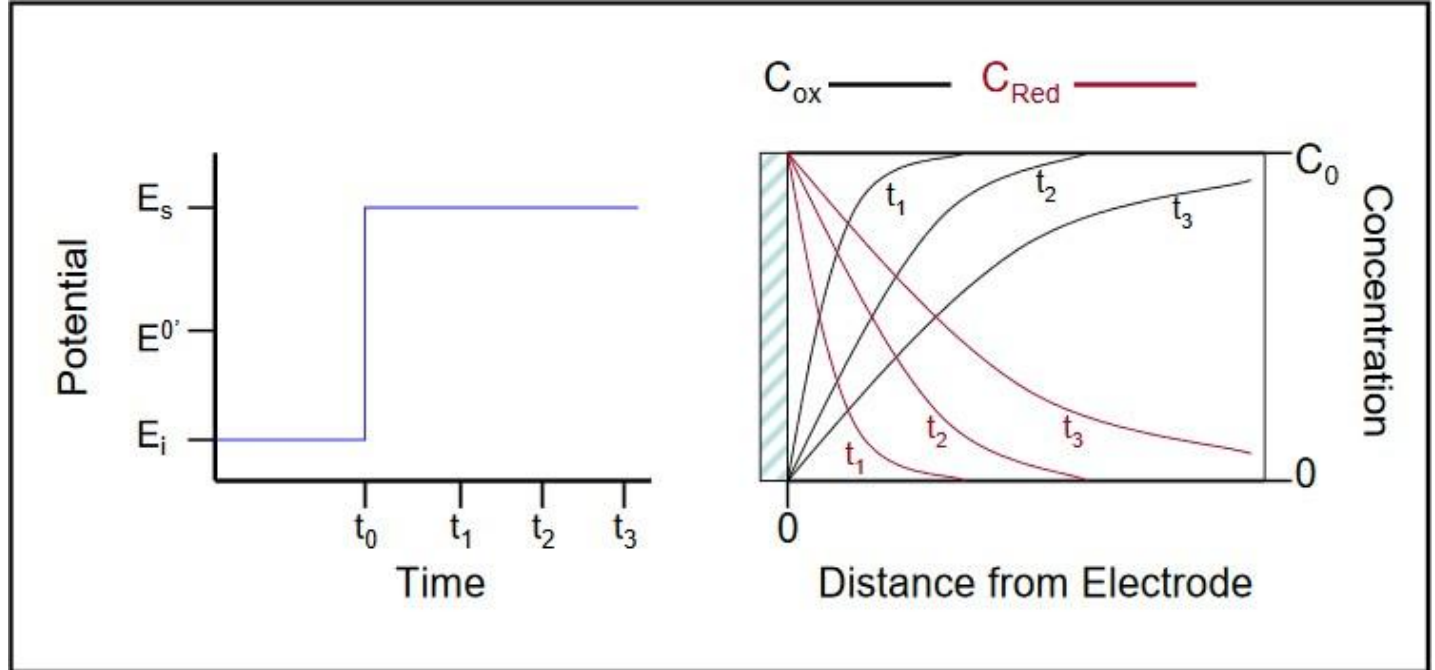
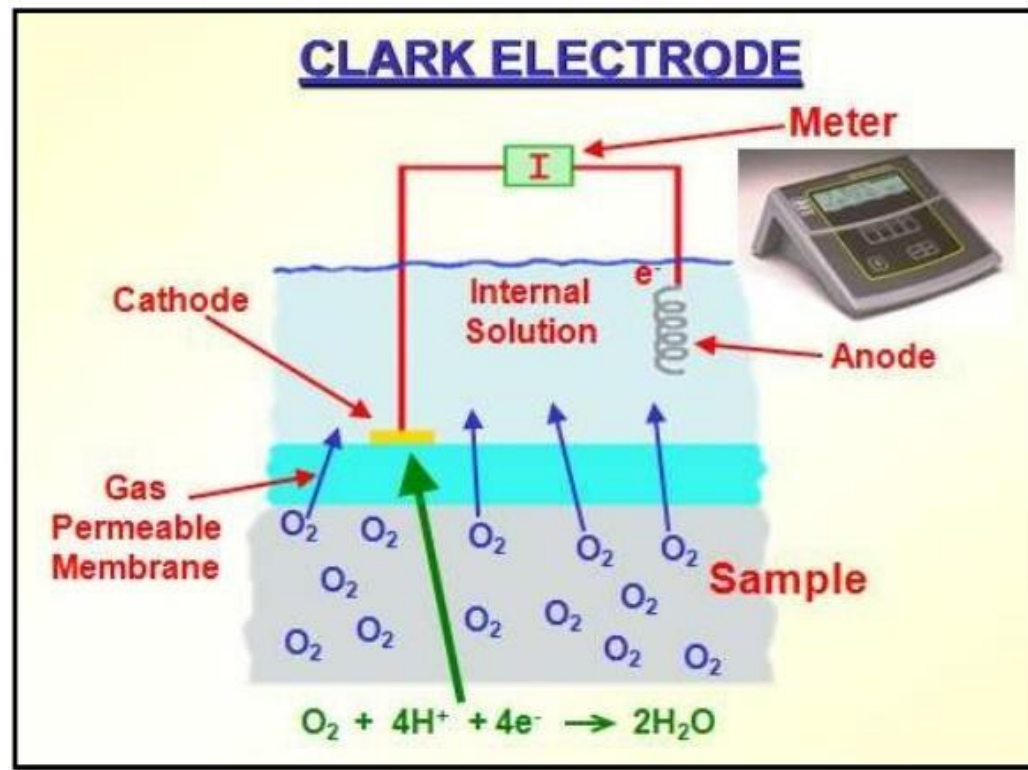
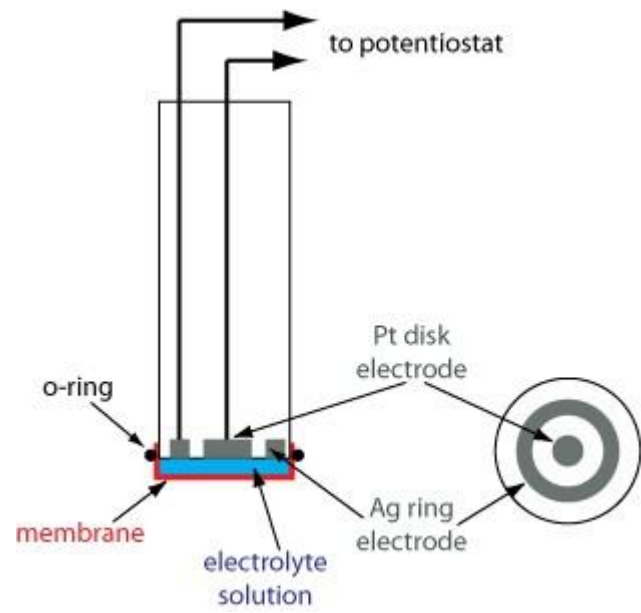

Fig. 5.8 Concentration profiles for a membrane-covered electrode. (a) The initial profile; (b) the development of concentration gradients through the different phases during attainment of steady state.



Applied potential
-0.7 V vs. Ag/AgCl



Dissolved Oxygen Electrode /Sensor
Industrial Type Model : MS DO 714

OXYGEN PROBE

The cathode should possess: high catalytic activity for the reduction of O_2 , (large exchange current), sufficient electrical conductivity (low adsorption of organic impurities or O_2), it should be inert, it should exhibit a large overvoltage for the decomposition of water (no hydrogen liberation), it should permit the required construction operation (e.g. sealing into glass)

Pt and Au are the most used materials

The gas permeable membrane protects the electrodes from contamination, provides for reproducible conditions of oxygen transport and minimize undesirable changes in electrolyte composition. Ideally, it should be with low permeability and high diffusivity for oxygen.

Non-hydratable polymers as polytetrafluoroethylene (PTFE), polypropylene (PP) and polyethylene (PE) are generally used. Alternatively elastic rubber or silicone are useful, even though less stable in alkaline medium.

The anode is Ag/AgCl and a neutral or alkaline electrolyte is used in the final assembling.

Conventional carbon based probes:

- graphite
- carbon paste
- pyrolytic graphite
- glassy carbon

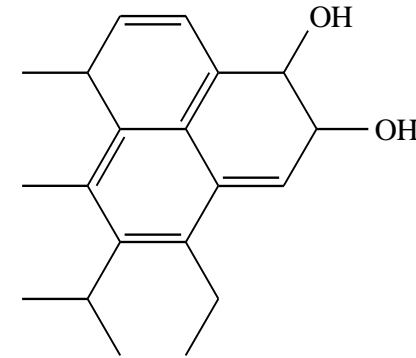
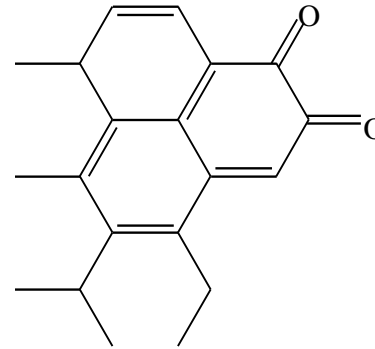
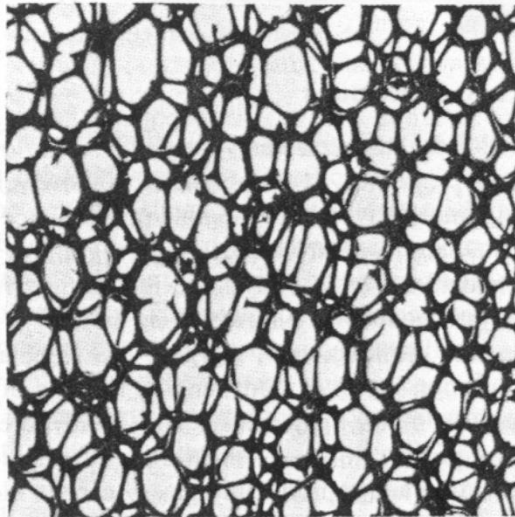
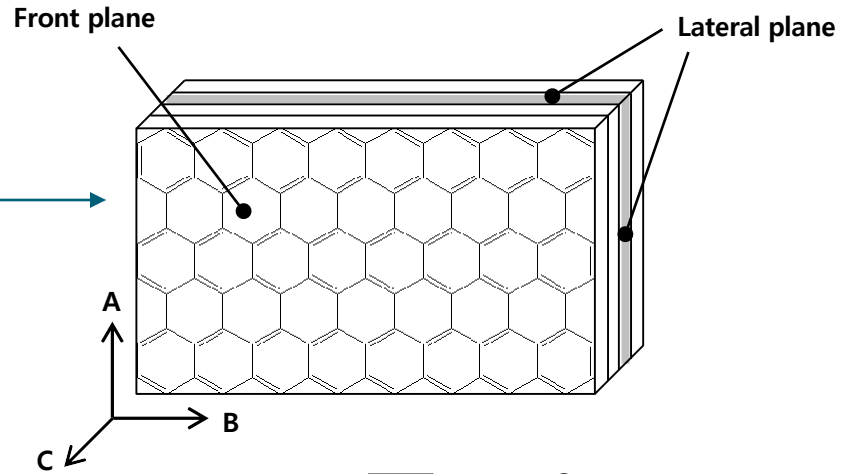

VLab-98

Printing electrodes: serigraphy

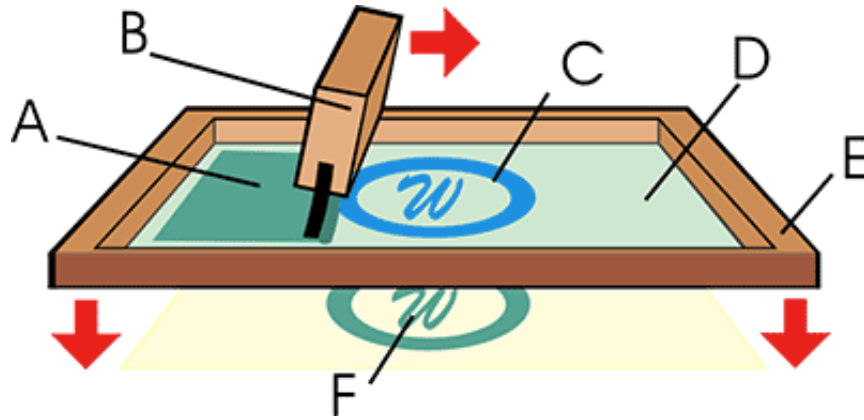

- A. ink; B. squeegee;
- C. printing mask;
- D. printing mesh;
- E. frame; F. printed ink

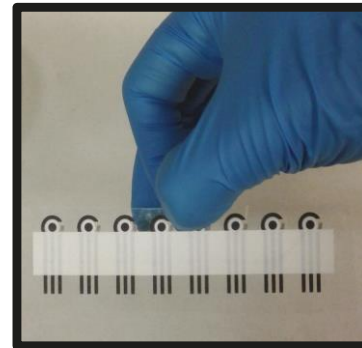
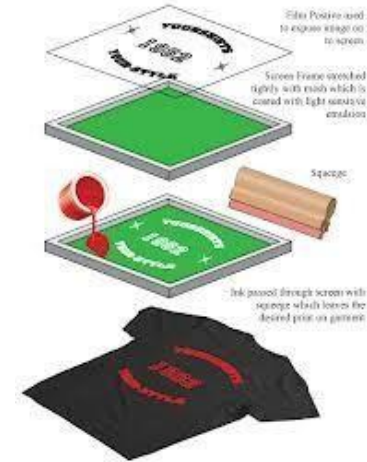

Advantages:

- Dimension
- Disposable
- Low-Cost

DISPOSABLE SCREEN-PRINTED CARBON ELECTRODES

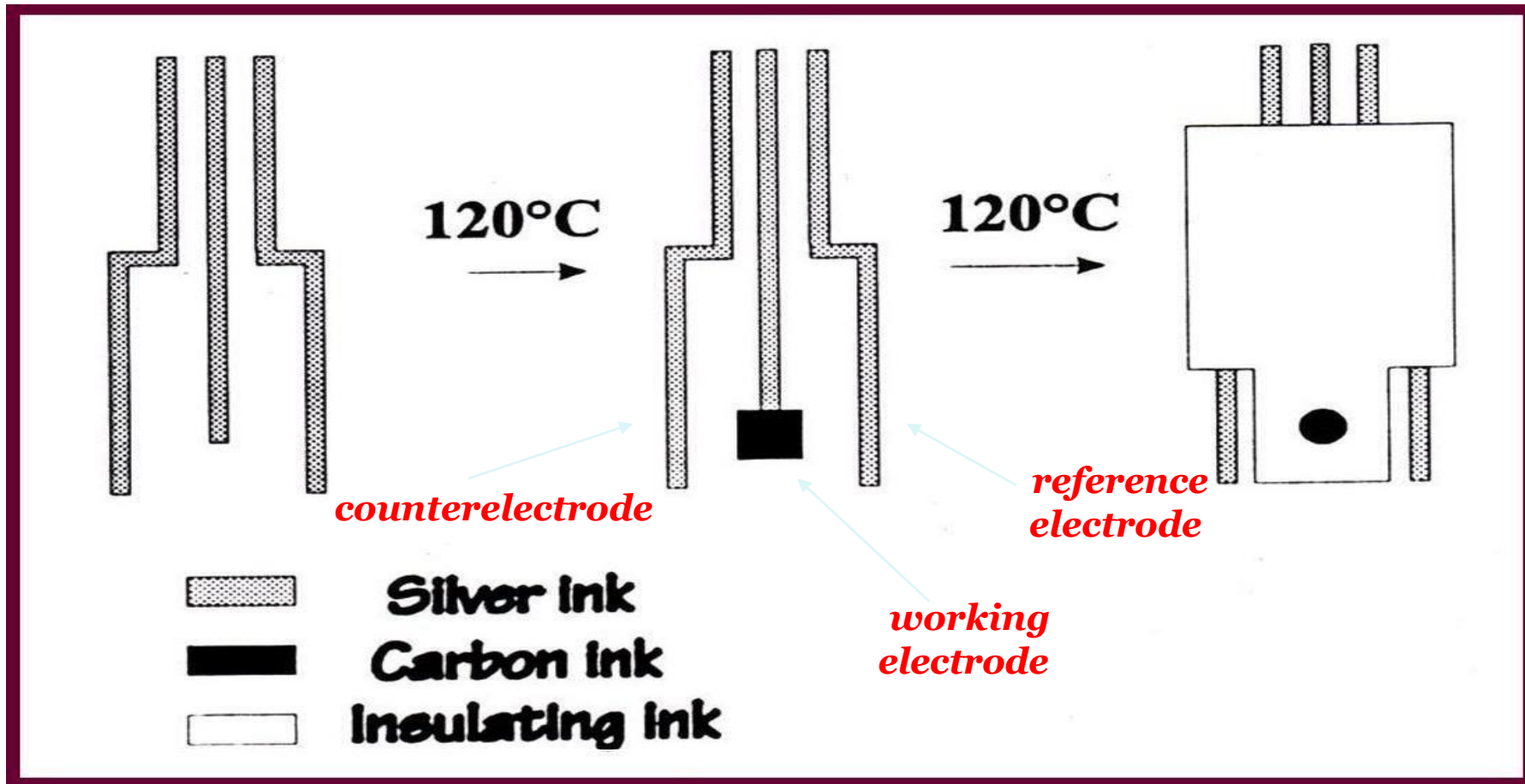

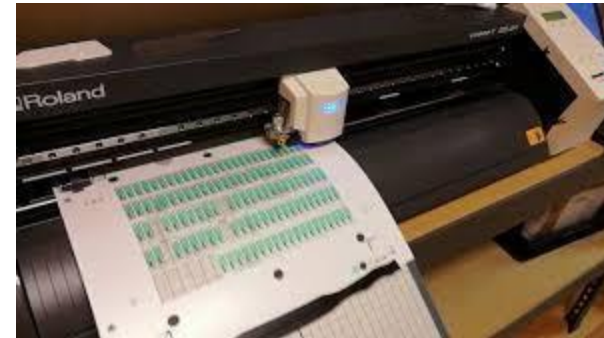
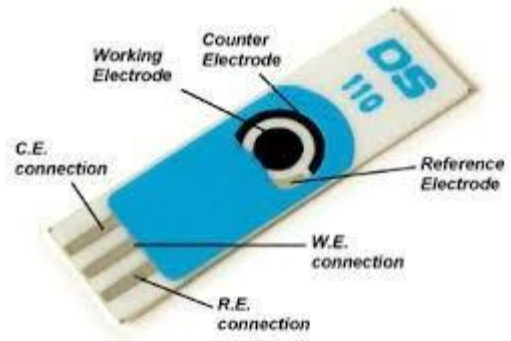

In **voltammetria** vengono utilizzati 3 elettrodi (riferimento, lavoro e contro elettrodo) ed un potenziostato. Infatti, poichè $E = iR$, per controllare accuratamente E durante la scansione è necessario far avvenire le reazioni redox (passaggio di corrente) tra l'elettrodo di lavoro ed un contro elettrodo

La corrente passa tra il contro elettrodo (auxiliary) e l'elettrodo di lavoro

Il potenziale applicato è tra l'elettrodo di riferimento e l'elettrodo di lavoro

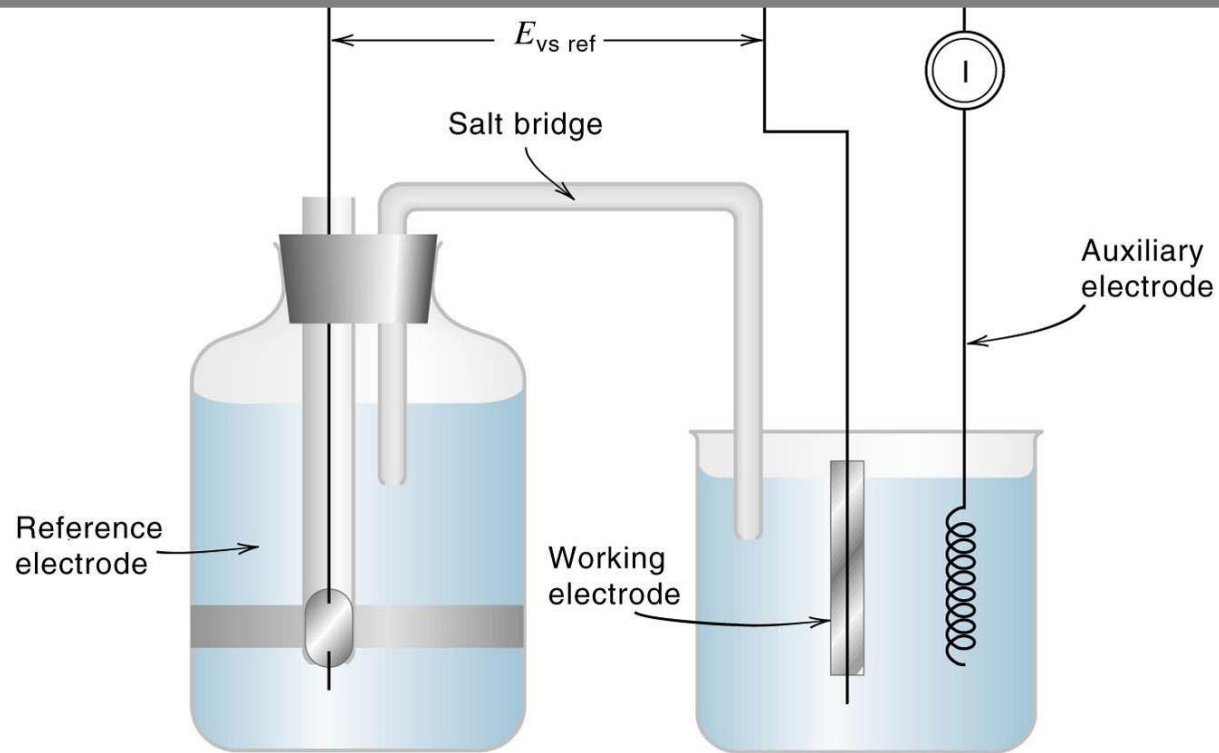

In **Amperometria** si possono usare 2 Elettrodi (Riferimento e Lavoro) purchè l'area dell'elettrodo di riferimento sia molto maggiore di quella dell'elettrodo di lavoro

cella per misure voltammetriche.

Il picco voltammetrico si forma in soluzioni quiescenti (senza agitazione)

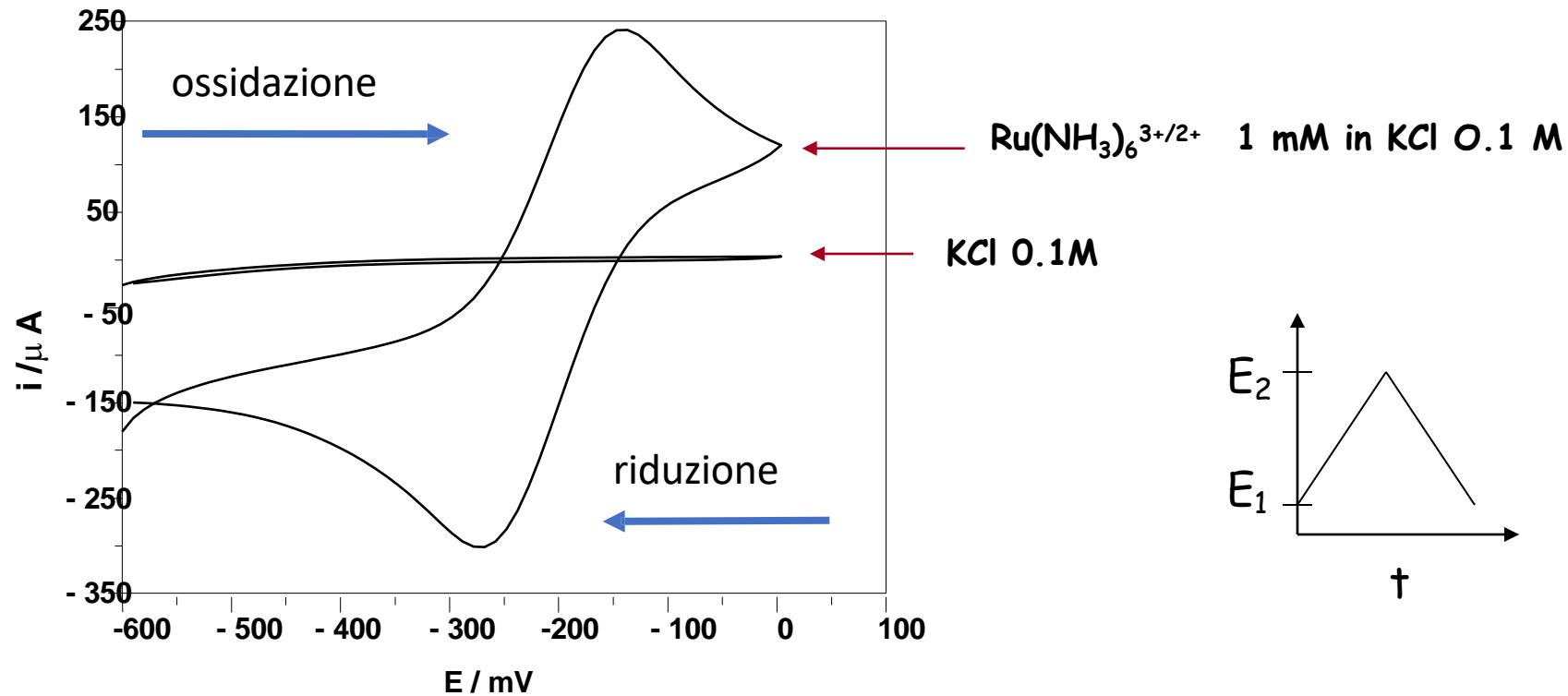

Elettrodo di carbone vetroso vs, SCE; velocità di scansione 50 mV/s

Nella **voltammetria ciclica** il potenziale viene invertito ad un certo punto e viene effettuata una scansione in senso inverso. Viene utilizzata per studiare reazioni redox ha caratteristiche analitiche simili alla voltammetria lineare

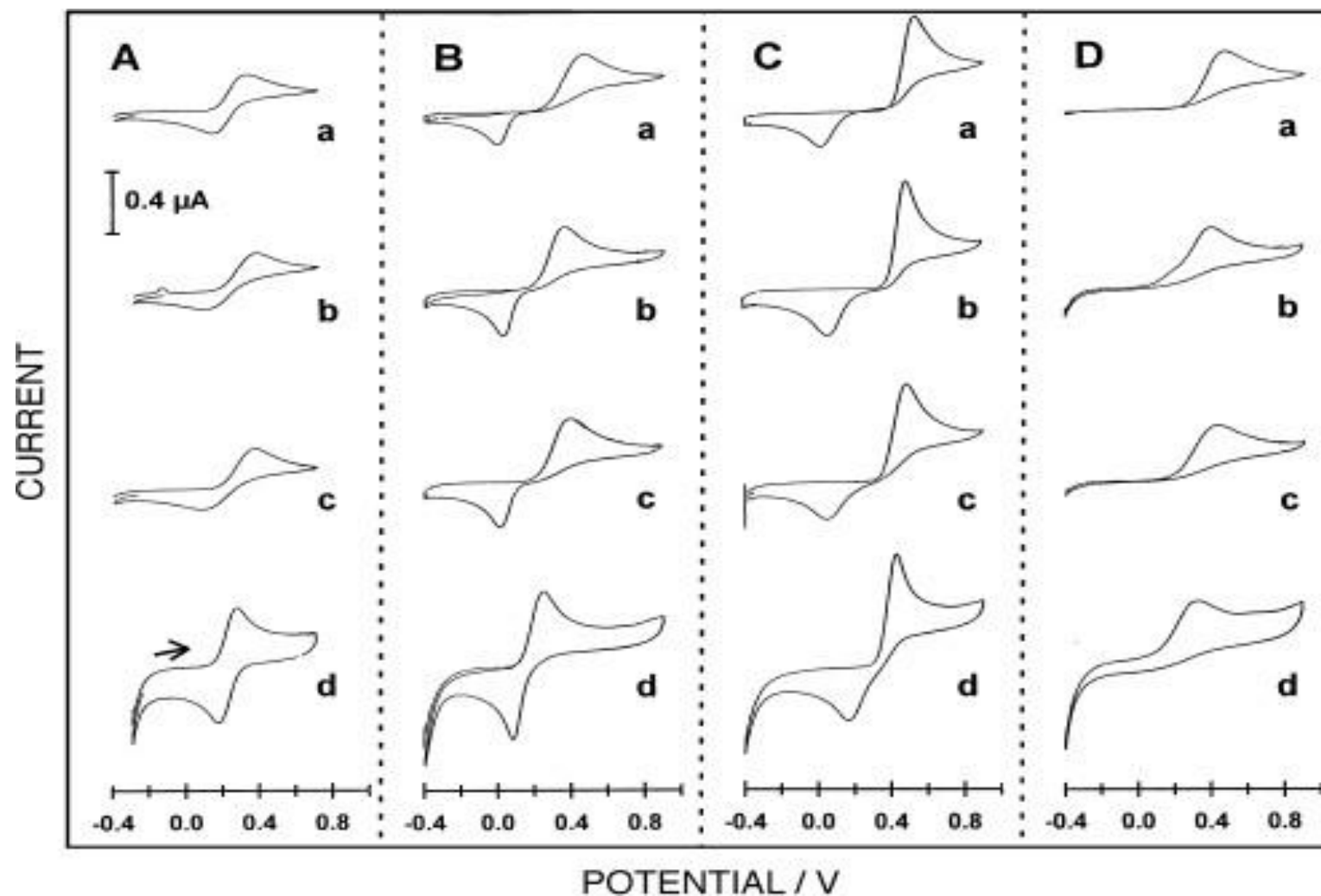

Cyclic voltammeteries of ferricyanide (A), catechol (B), acetaminophene (C), ascorbic acid (D) carried with dfferent screen-printed electrodes: Dupont (a), Ercon (b), Acheson (c) Gwent (d). Supporting electrolyte; KCl 0.1M (A), scan rate 20 mV/s.

Screen-Printed Electrodes

Sensors

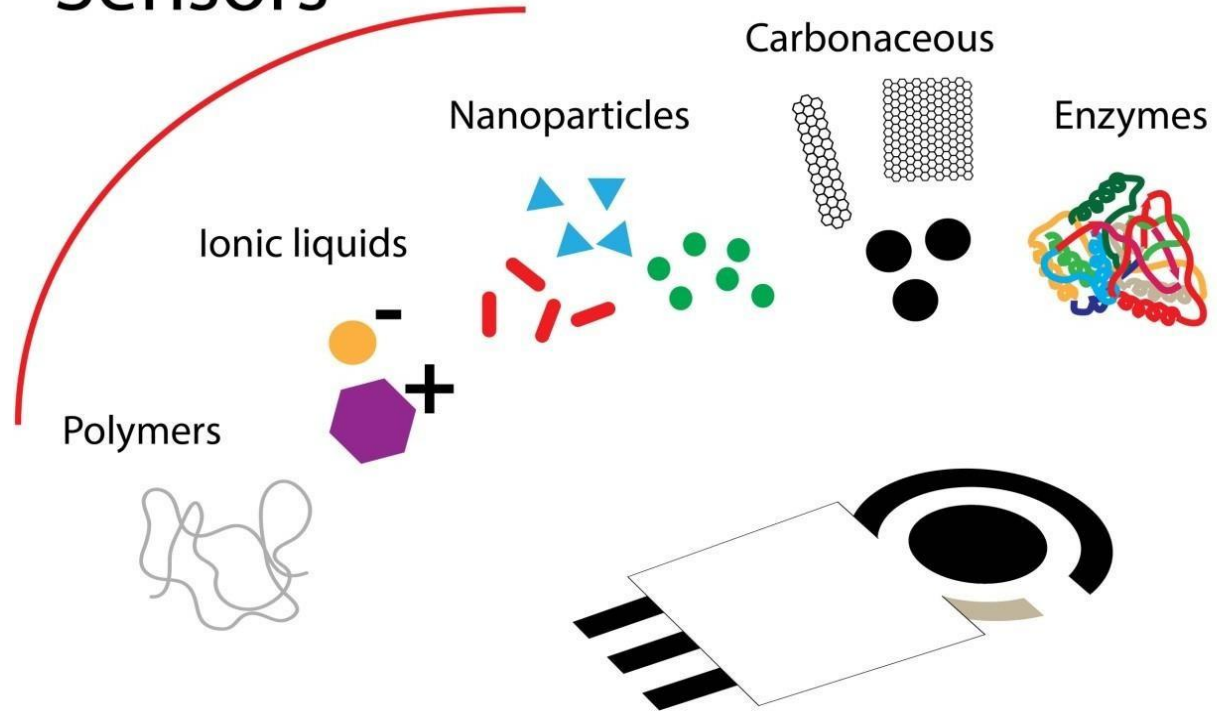

Biosensors

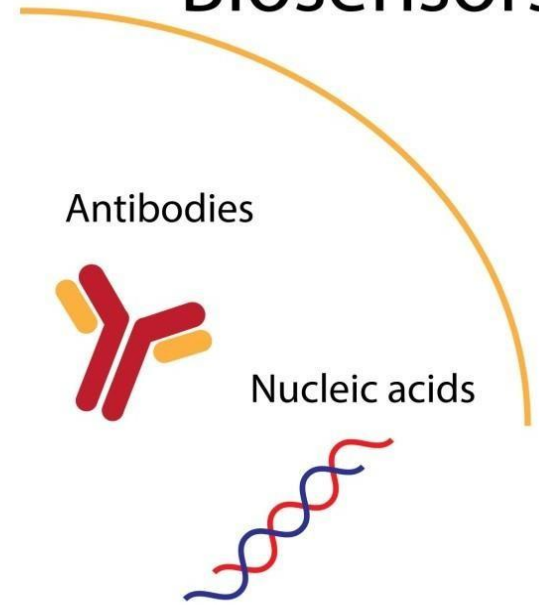

Screen-printed electrochemical (bio)sensors

How do we tune them?

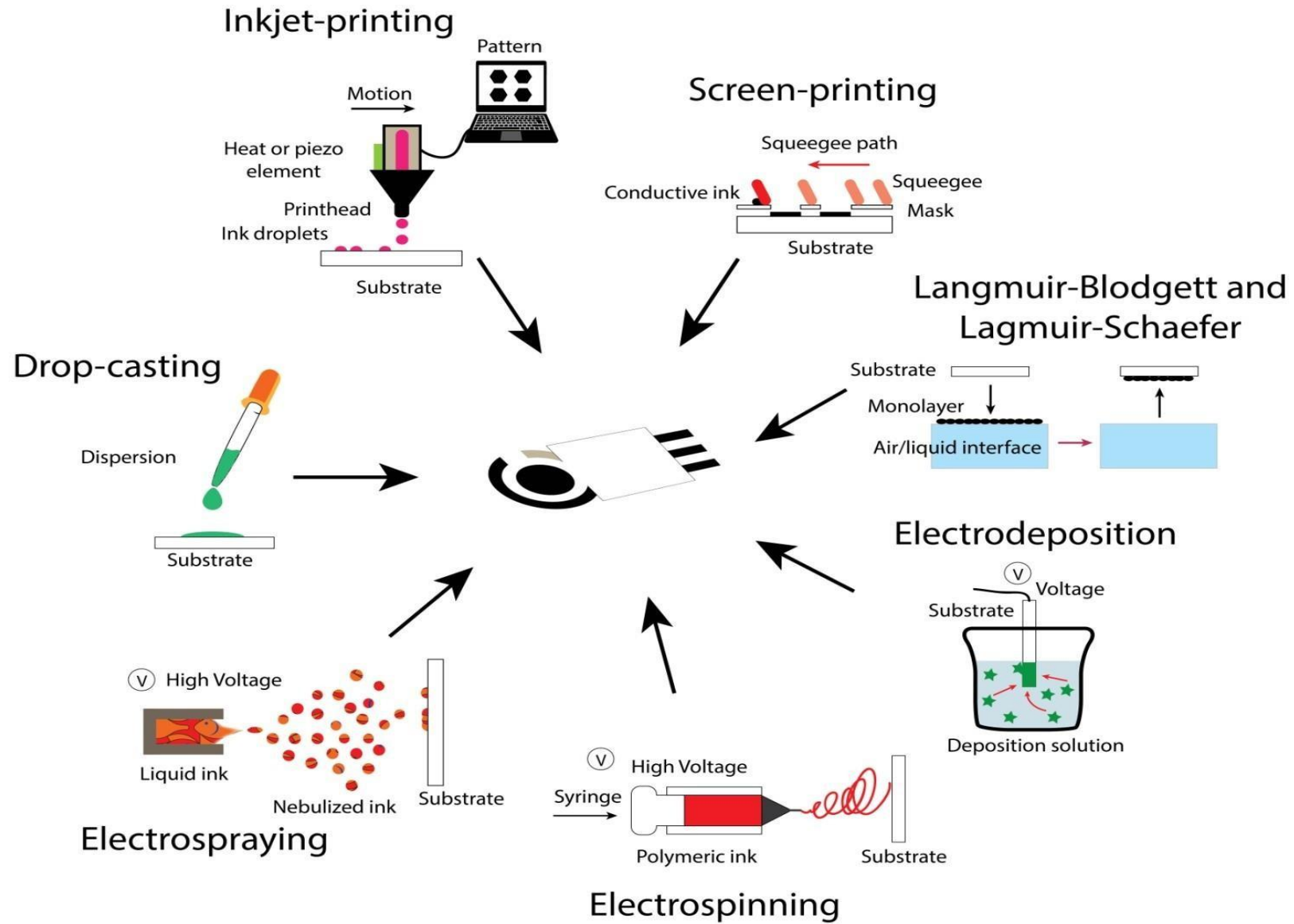

ENZIMI

i dosaggi di substrati basati su kits sono end-point



Figura 10.3 Dosaggio spettrofotometrico del piruvato con lattico deidrogenasi e NADH (dosaggio a termine con reazione semplice).



Figura 10.9 Dosaggio spettrofotometrico di G6P, G1P, glucosio, fruttosio + F6P in una singola cuvetta con G6P deidrogenasi (G6P-DH) e NADP⁺; fosfoglucomutasi (PGM); esocinasi (HK) e ATP; G6P isomerasi (PGI) (dosaggio a termine con reazioni accoppiate).

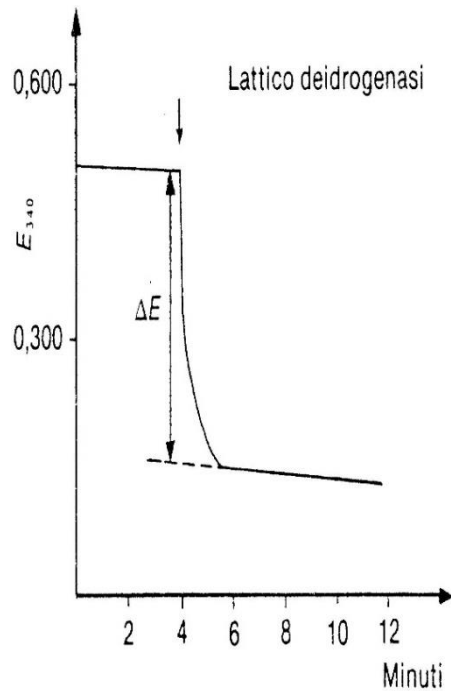

Enzyme electrode

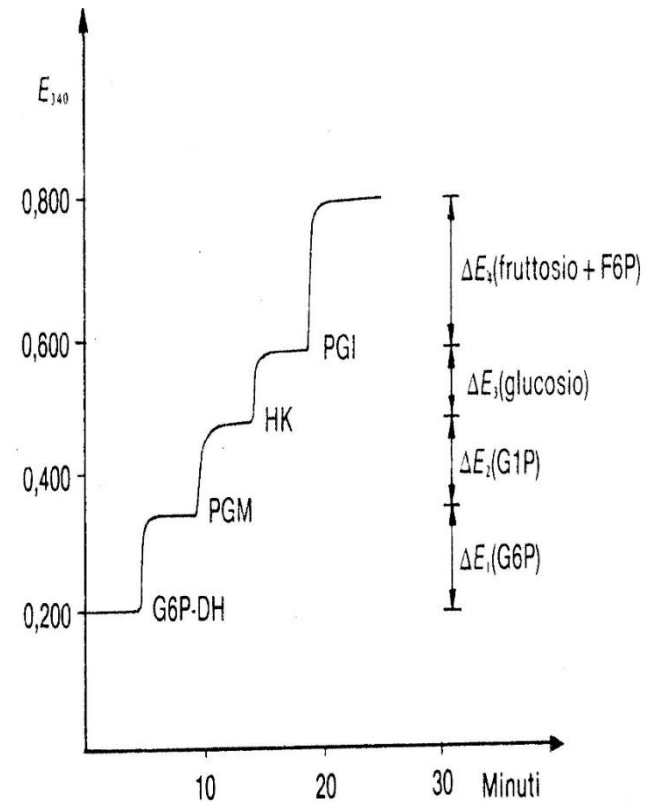
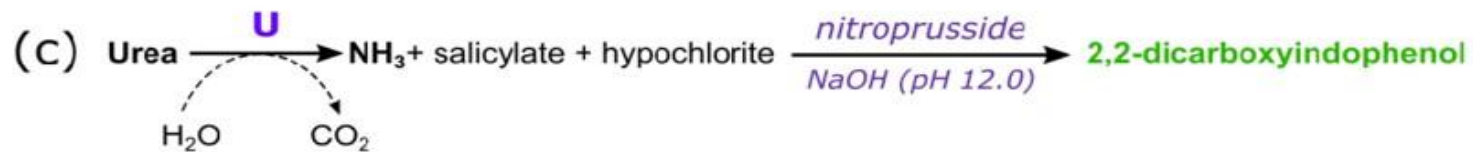
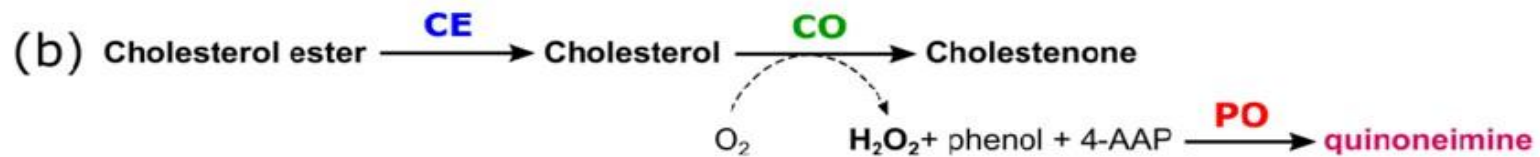
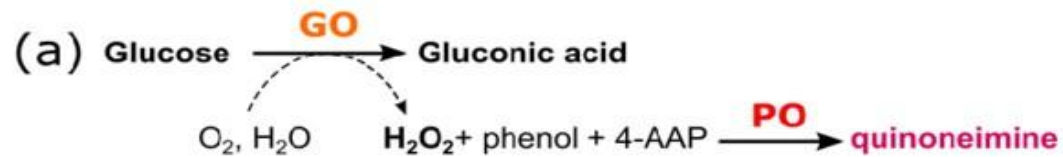
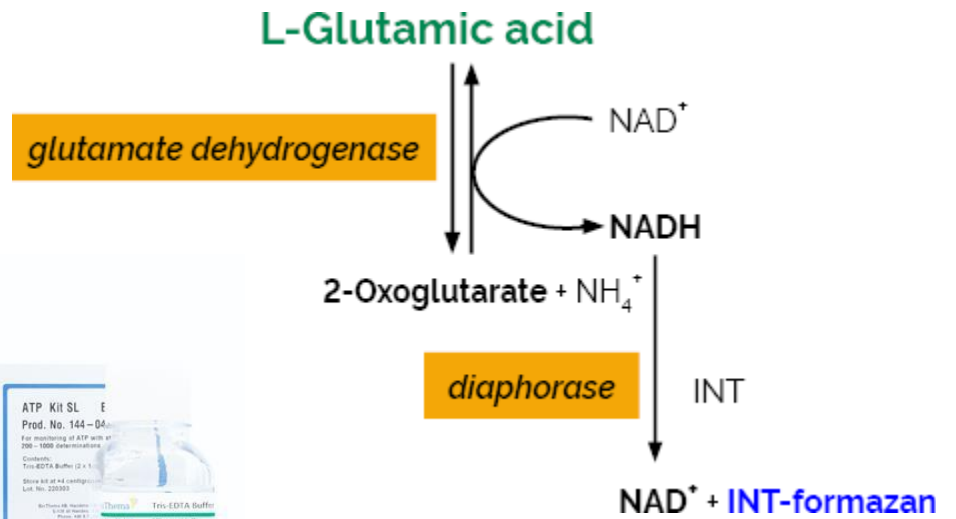
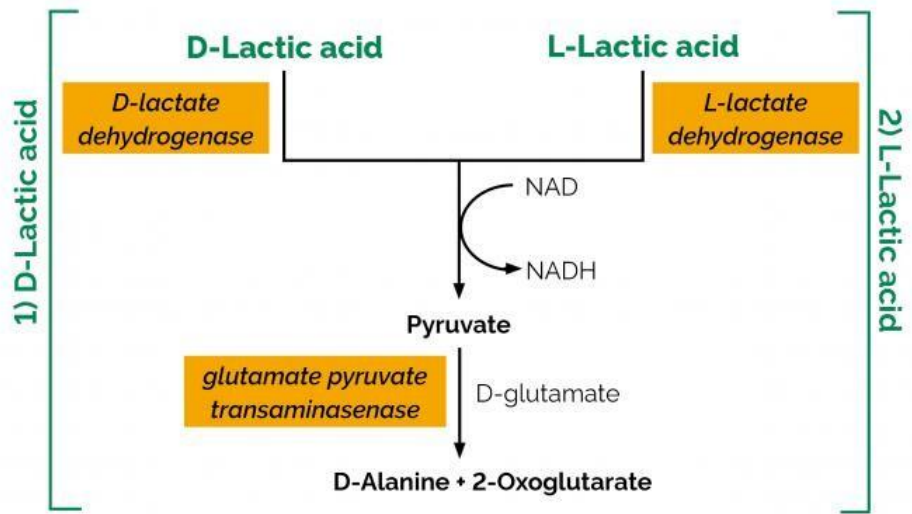
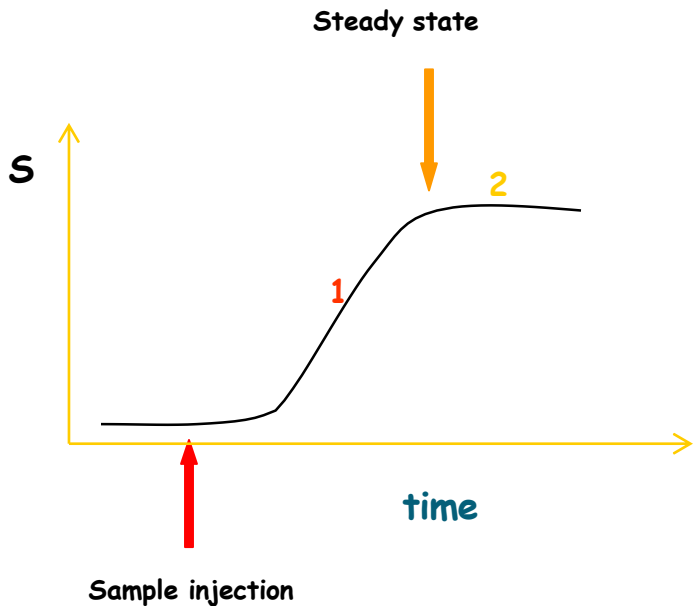
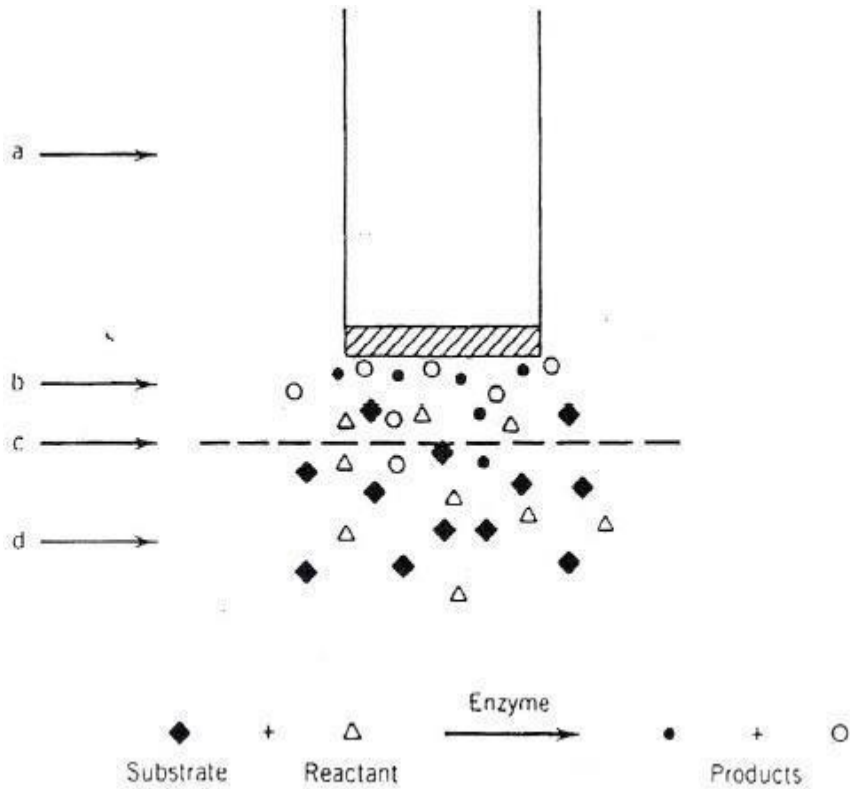

The response of a good enzyme electrode should be independent by enzymatic and electrode catalytic reactions

THE BIOLOGICAL ELEMENT SHOULD HAVE:

GOOD SPECIFICITY (HIGH SELECTIVITY) FOR THE ANALYTE(S) STABILITY IN

OPERATING CONDITIONS as t , pH, μ (ionic strength)

RETENTION OF SUFFICIENT BIOLOGICAL ACTIVITY WHEN
IMMOBILISED

NO (VERY LOW) INHIBITION BY THE SAMPLE

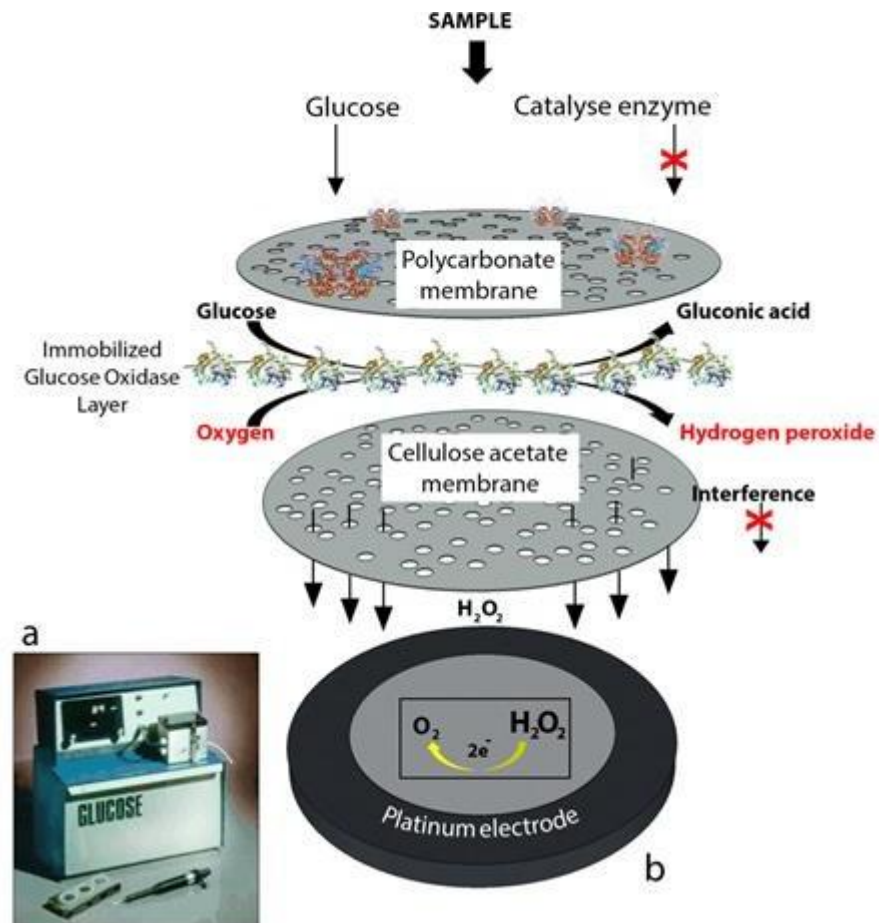
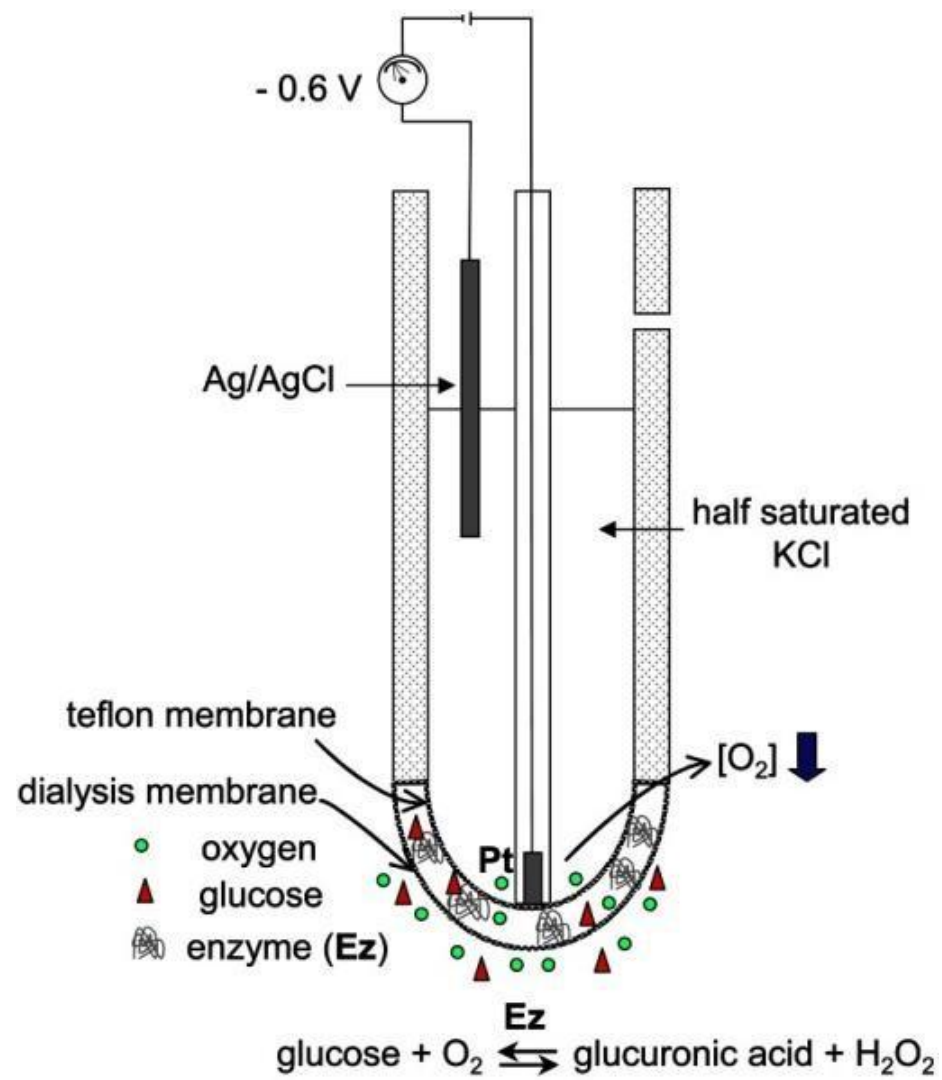

Ossidazione

Per la determinazione della H_2O_2 si applica un potenziale di +0.6 V vs. Ag/AgCl

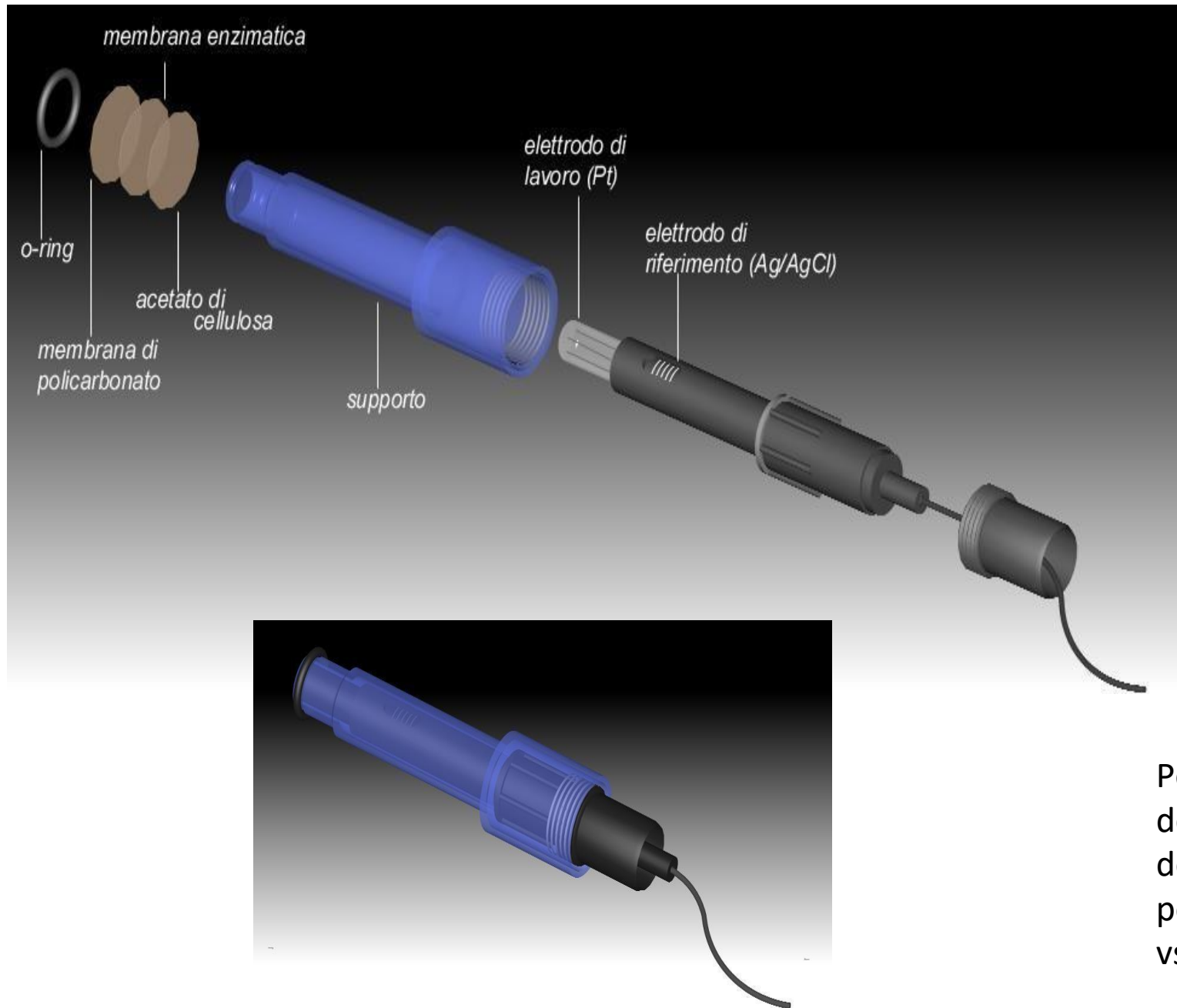

Riduzione

Per la determinazione dell' O_2 si applica un potenziale di -0.7 V vs. Ag/AgCl

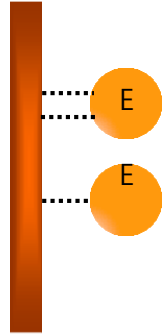

adsorption

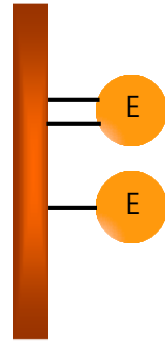

covalent
binding

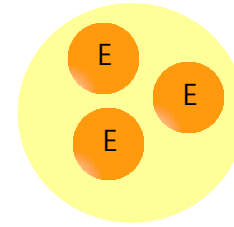

entrapment

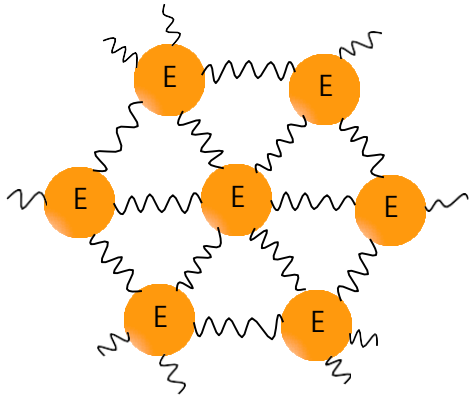

cross-linking

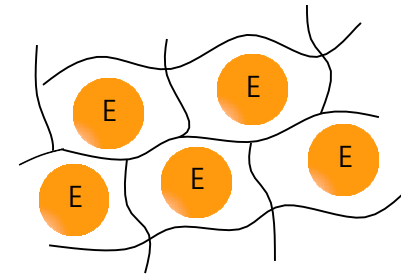

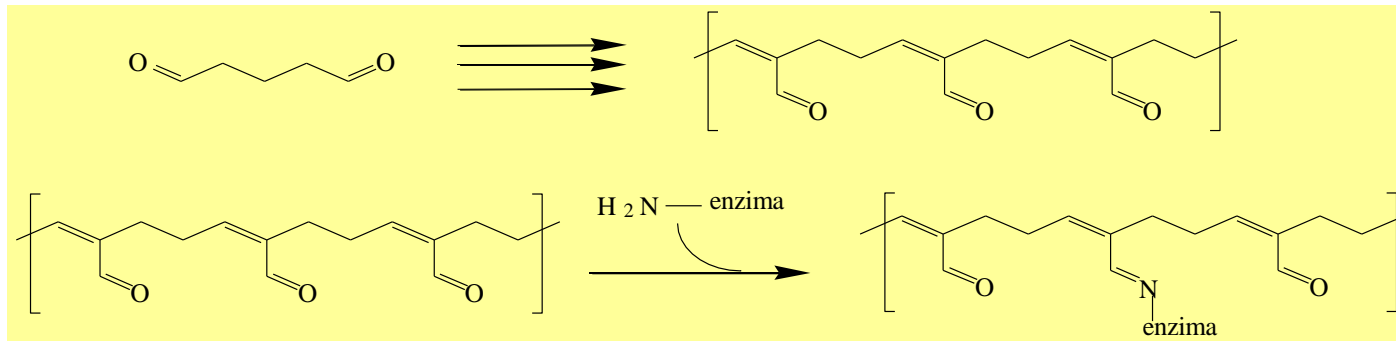

glutaraldehyde reactions: polimerization and lysine amino group

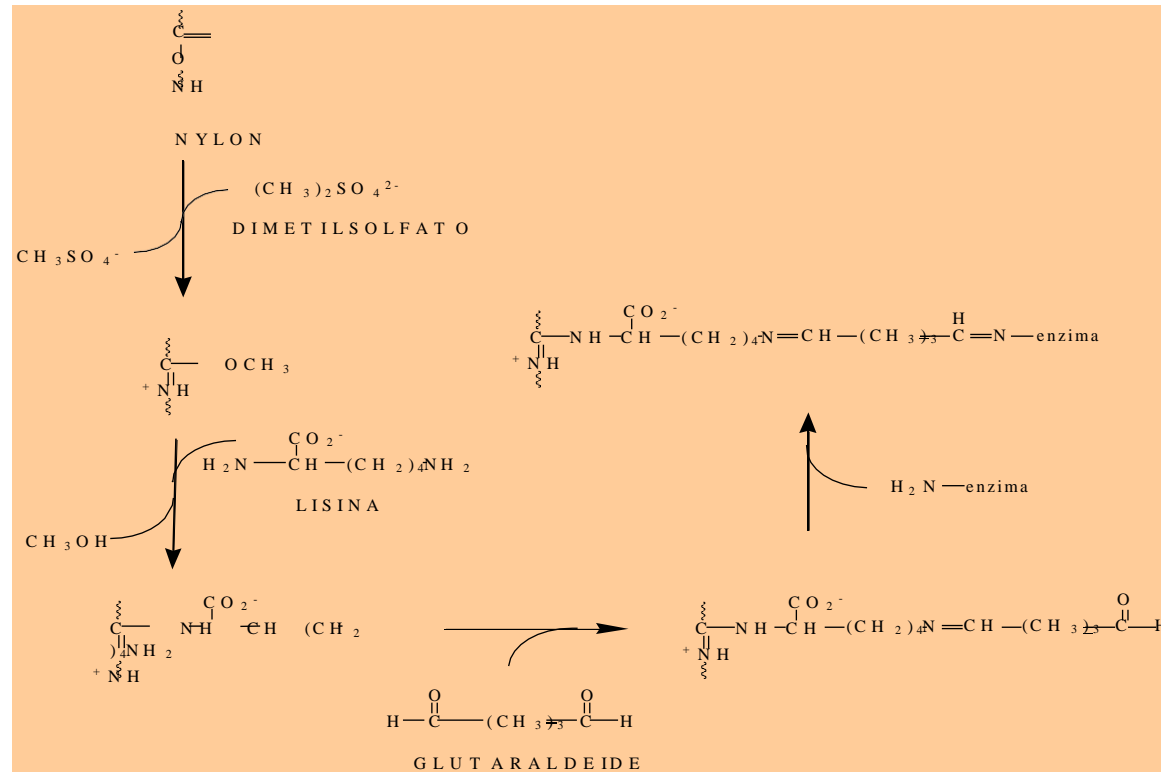
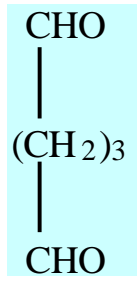

Immobilisation via carbodiimide

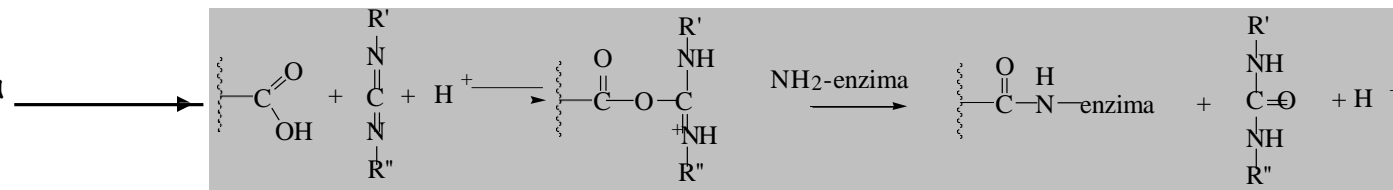

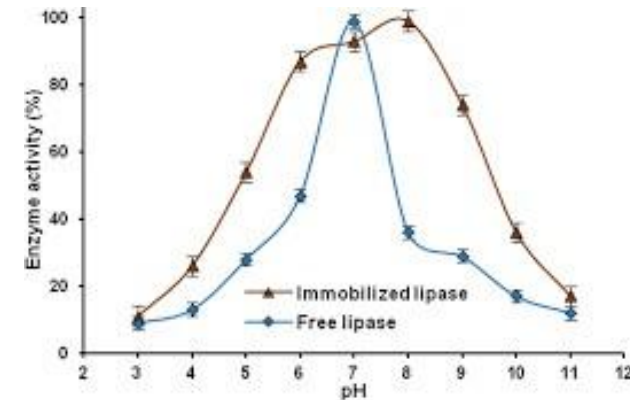
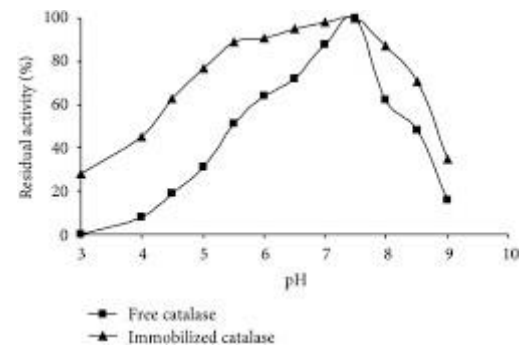
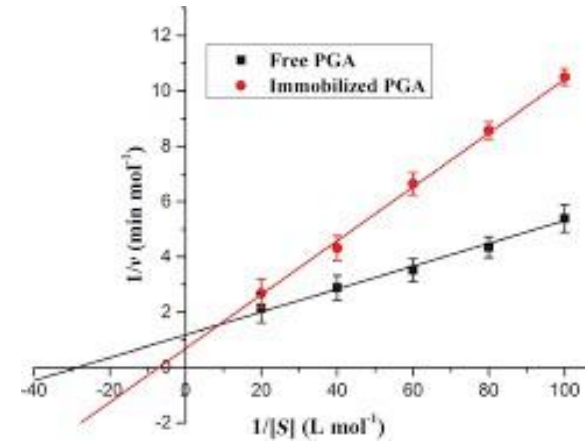
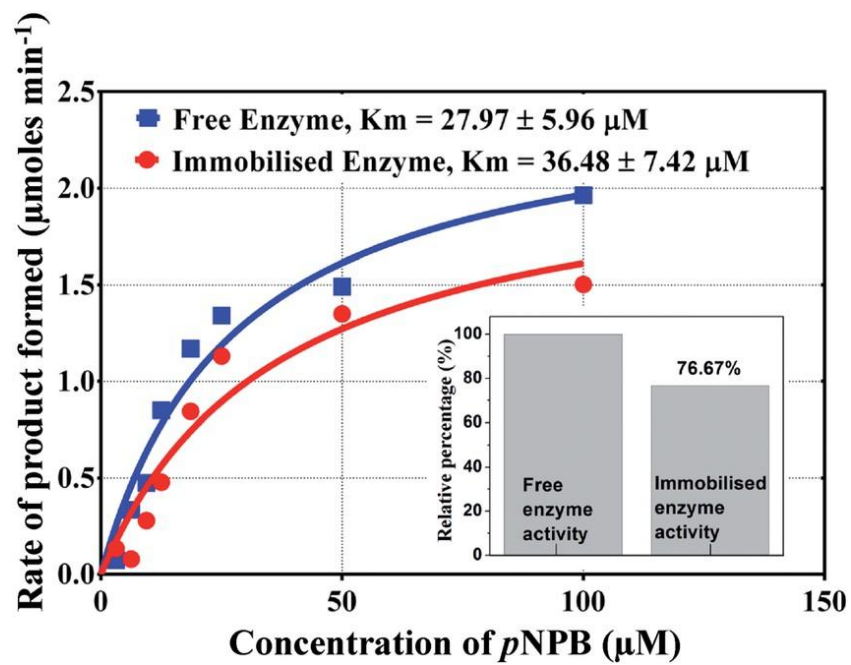

The immobilised enzyme has always a higher (apparent) K_m , a shifted and larger optimum pH and lower enzymatic activity compared to the enzyme in solution

Enzyme electrodes are generally classified according to the mechanism of the electron transfer:

1. First generation: the enzyme is immobilised using a membrane that is in contact with the electrode surface. Usually there are other membranes to protect and regulate diffusion. Response time at the steady state is on the order of minutes

2. Second generation: electron transfer occurs via an electrochemical mediator in solution. The mediator shuttles electrons between the enzyme and the electrode. Faster response times.

3. Third generation: direct exchange of electrons between the electrode and the enzyme. Very fast response time.

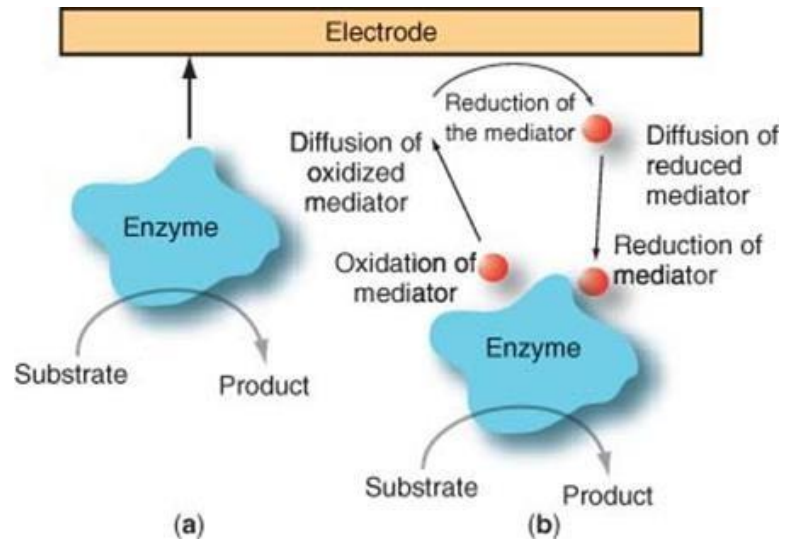

Seconda e terza generazione

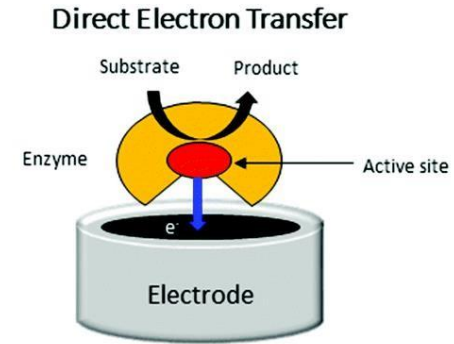

Mediated electron transfer

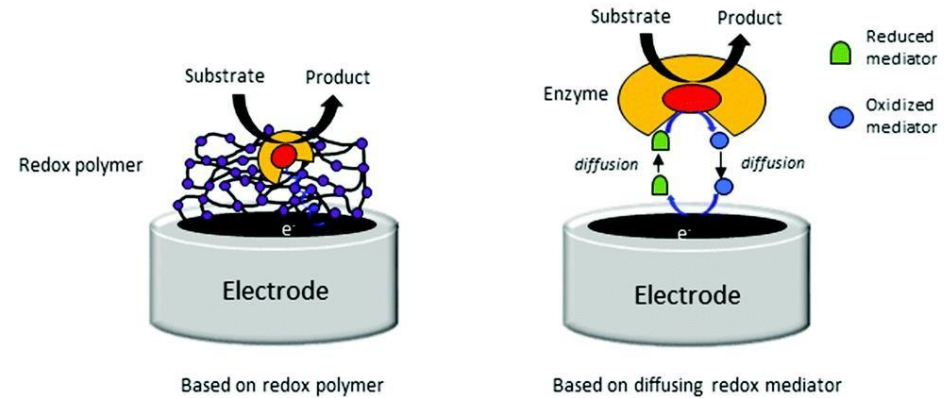

A good electrochemical mediator characteristics :

- rapid reaction with the enzyme
- rapid and reversible electron transfer rate
- low overpotential for the redox reaction
- pH independent
- stability in the reaction medium in both redox forms
- Should not react with the dissolved oxygen in solution
- no toxicity

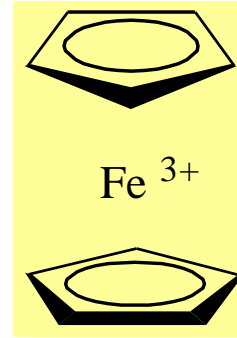

ferrocene is an excellent mediator for the oxidation of glucose catalysed by glucose oxidase

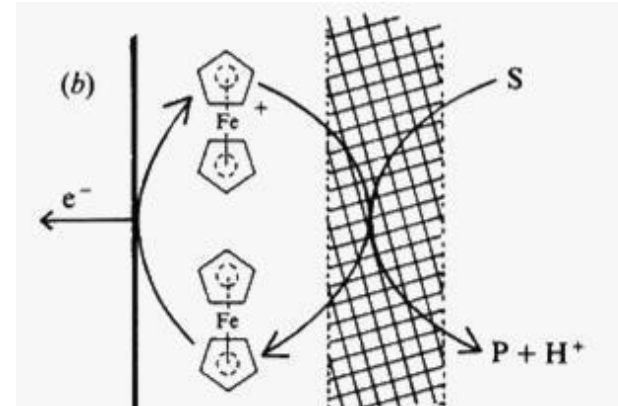
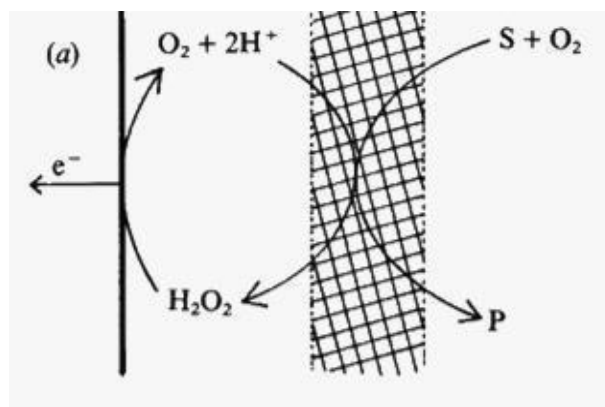
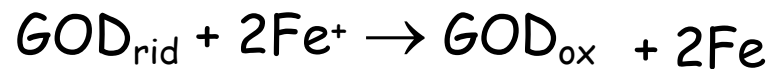

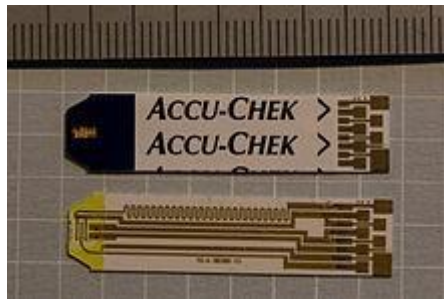

SIMPLE STEP BY STEP FUNCTION



1. Insert the ExacTech test strip in the meter and then place a blood sample on the target area.



2. Press the button immediately. The meter is now analysing the sample. 0 SECS



3. After a 30 second countdown, the result is displayed. 30 SECS



The ExacTech Blood Glucose Meter is shown Actual Size

Test Strips

- When blood added, glucose is oxidized by enzyme coated on working electrode
- Voltage applied between working and reference electrode
- Measure current between working and reference electrode

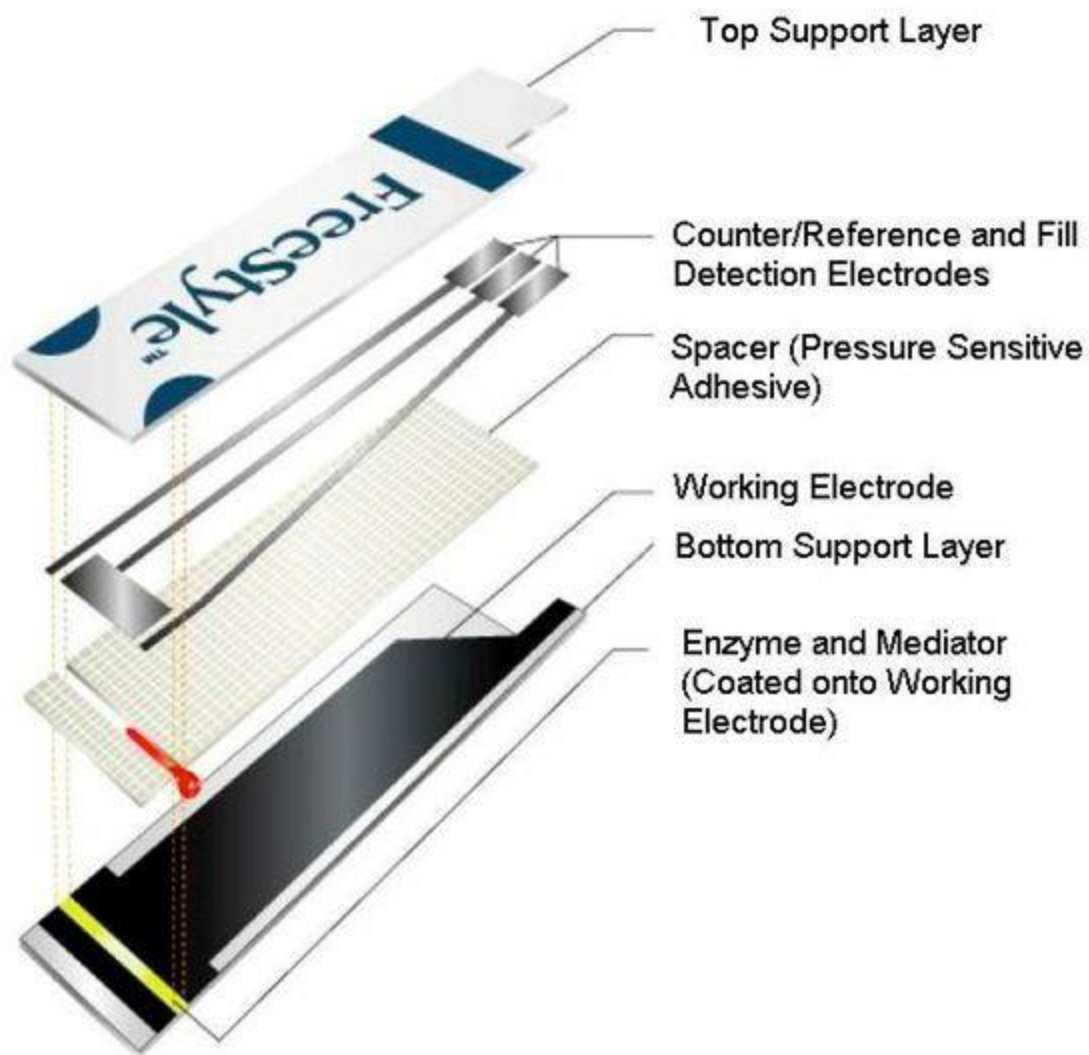

| NATURAL | E(V) vs. SHC | SYNTHETIC | E (V) vs. SHC |
|---------------------------|----------------|--------------------------|---------------|
| Cytochrome a ₃ | +0,29 | Esacyanoferrate(III) | +0,45 |
| Cytochrome c ₃ | +0,24 | 2,6-dichlorophenol | +0,24 |
| Ubiquinone | +0,10 | Indophenolo | +0,24 |
| Cytochrome b | +0,08 | Ferrocene | +0,17 |
| Vitamin K ₂ | -0,03 | N-metilfenazium sulphate | +0,07 |
| Rubredoxin | -0,05 | Metilene blue | +0,4 |
| Flavoproteins | da -0,4 a +0,2 | Ftalocyanin | -0,02 |
| FAD/FADH ₂ | -0,23 | Fenosafuranin | -0,23 |
| FMN/FMNH ₂ | -0,23 | Benzyl viologen | -0,36 |
| NAD ⁺ /NADH | -0,32 | Methyl viologen | -0,46 |
| NADP ⁺ /NADPH | -0,32 | | |
| ferredossina | -0,43 | | |

Third generation

Conducing salts

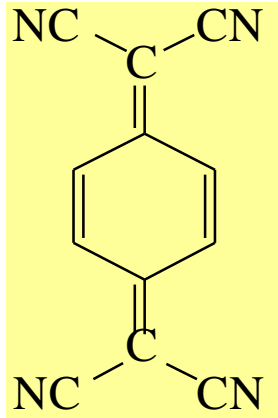

Tetracyanoquinodimethane (TCNQ)

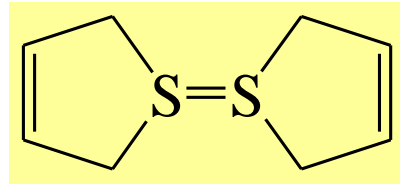

Tetra thiafulvalene(TTF)

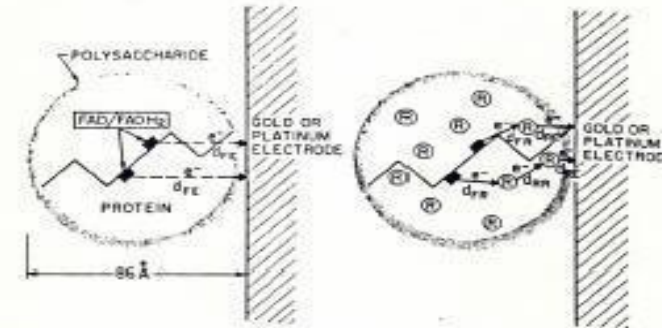
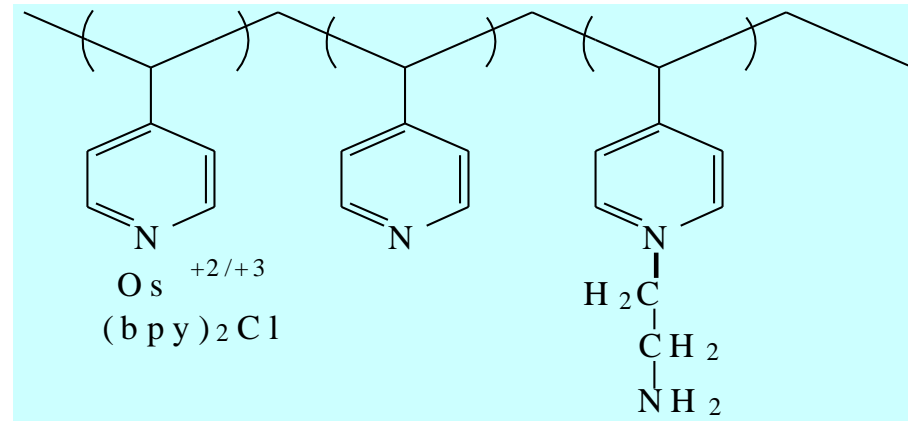

Figure 1. Schematic drawing of the glucose oxidase molecule, showing the electron-transfer distances involved in the various steps of moving an electron from its two FAD/FADH₂ centers to a metal electrode. Left: the enzyme before modification. Right: the modified enzyme, after chemical attachment of an array of electron-transfer relays.

Redox gel



Struttura dell' osmio biperidile legato a polivinilpiridina

**Reduced Prussian Blue is a selective catalyst
for H_2O_2 reduction**



A mediator can be also immobilized at the electrode surface giving rise to a **chemically modified electrode**

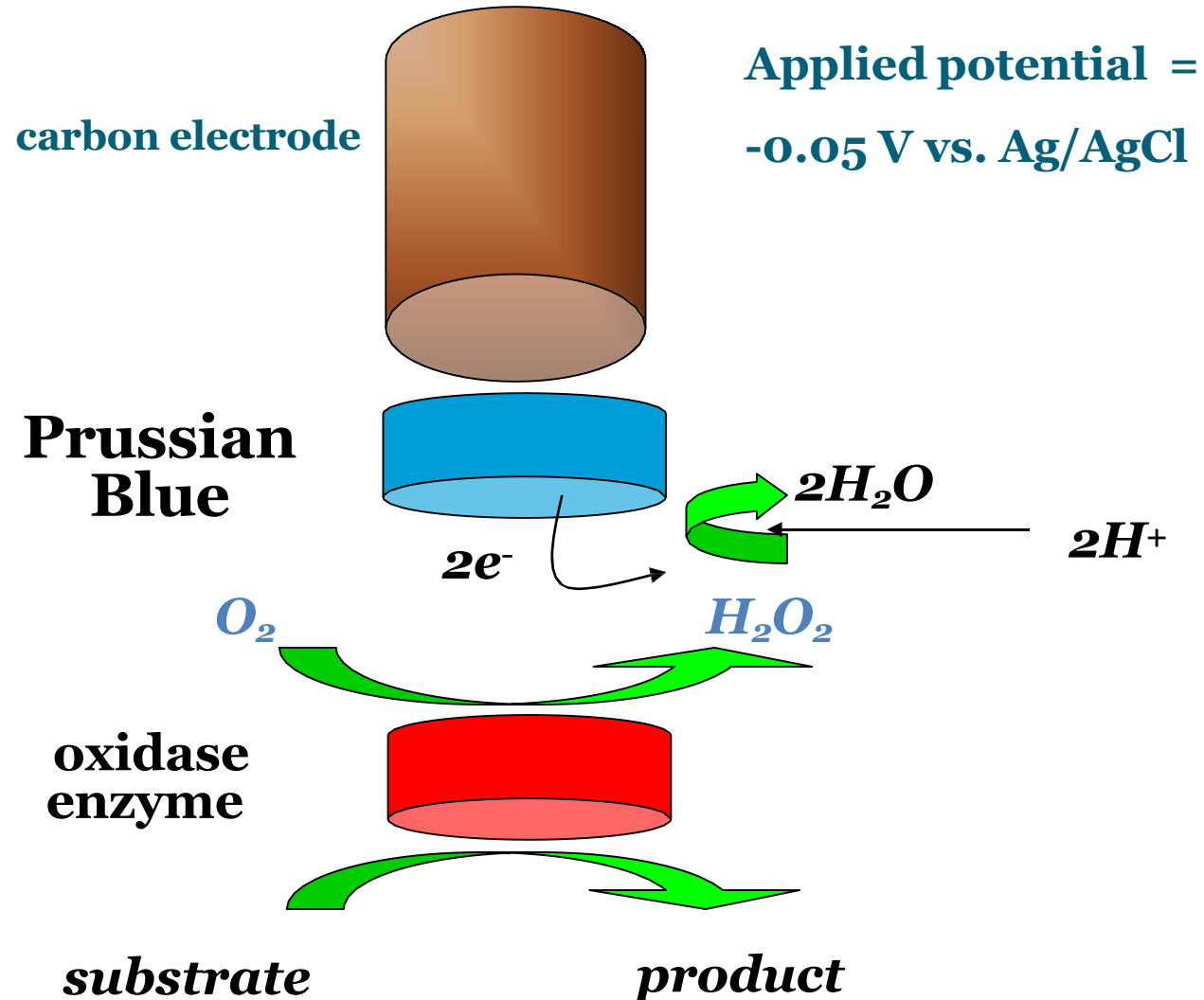

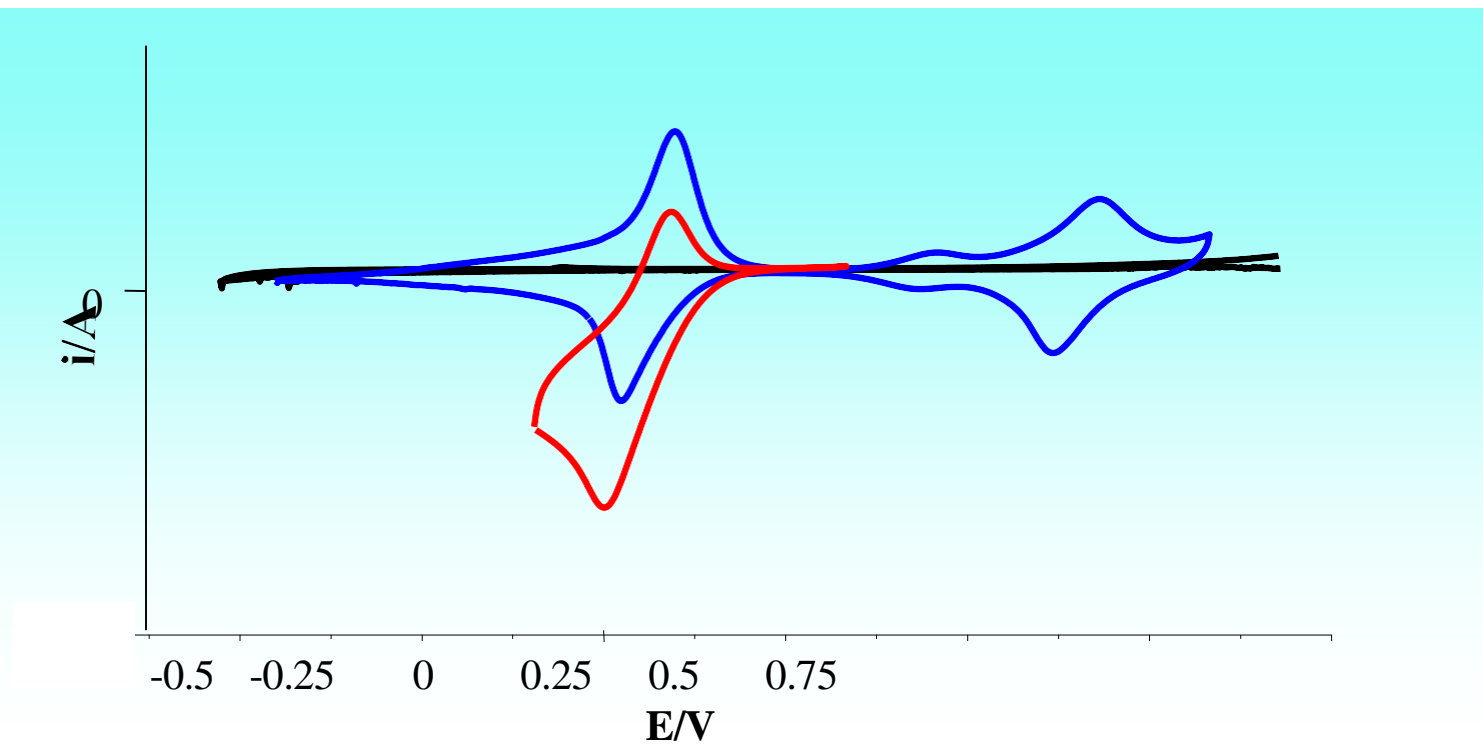

Bare electrode

Prussian Blue modified electrode

Prussian Blue modified electrode + H_2O_2

Selection of the applied potential

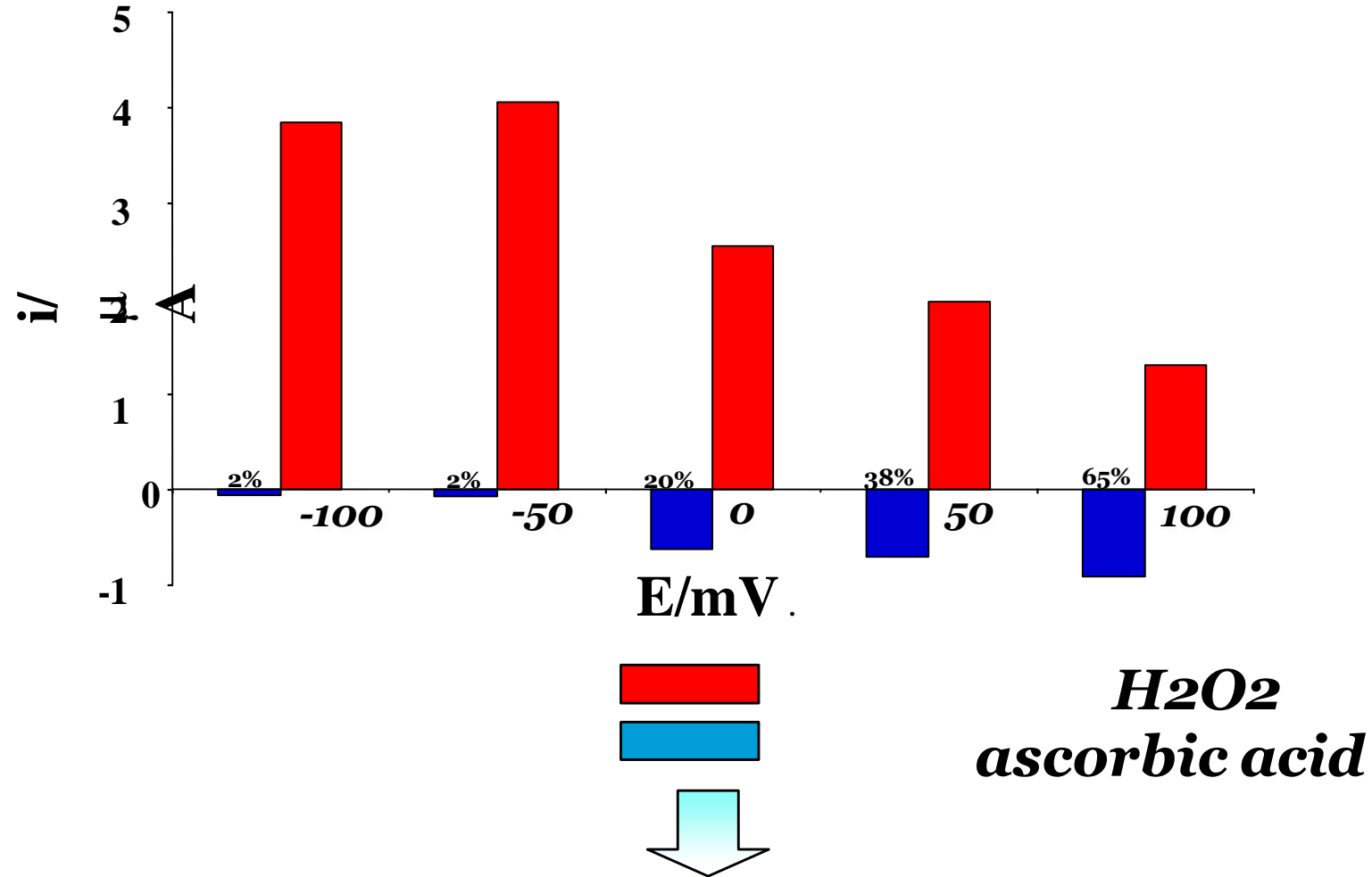

Potential selected - 50 mV vs. Ag/AgCl pseudo-ref.

Is this Nano?

Nanotechnology is a “*system of innovative methods to control and manipulate matter at near-atomic scale to produce new materials, structures, and devices*”.



Nanomaterials (NMs)

Materials in the range of 100 nm are considered to be nanoparticles. They exhibit a wide range of properties, including optical, electrical, catalytic, magnetic, and biological activity.



Considerations on the EU definition of a nanomaterial: Science to support policy making

Eric A.J. Bleeker*, Wim H. de Jong, Robert E. Geertsma, Monique Groenewold, Evelyn H.W. Heugens, Marjorie Koers-Jacquemijns, Dik van de Meent, Jan R. Popma, Anton G. Rietveld, Susan W.P. Wijnhoven, Flemming R. Cassee, Agnes G. Oomen

Is this Nano?

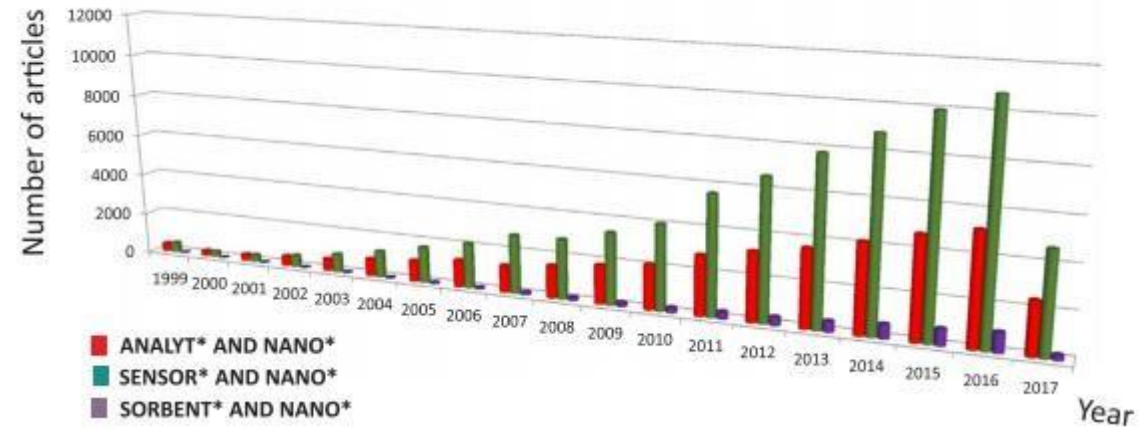
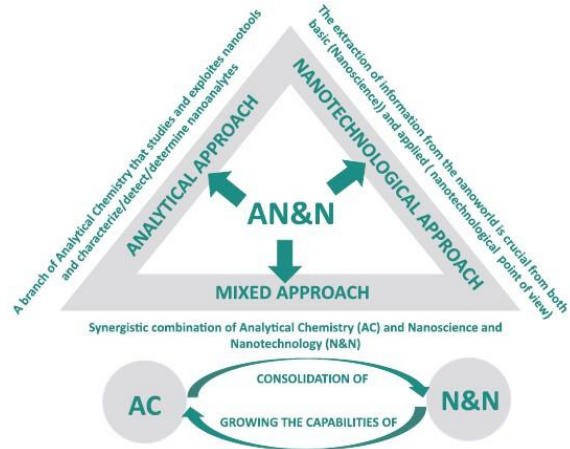
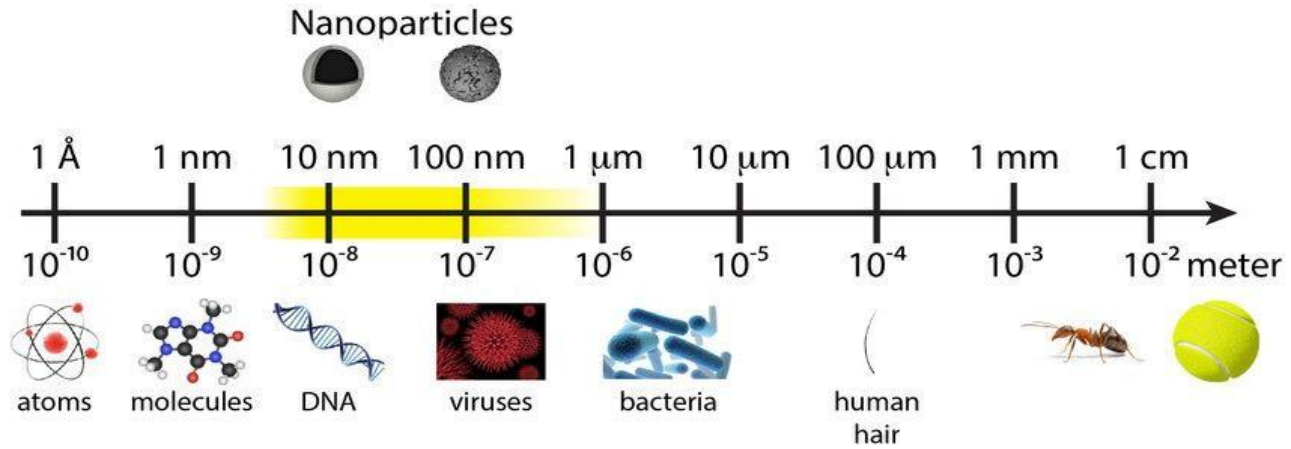

Nanomaterials

Nano-objects
Nano-particles

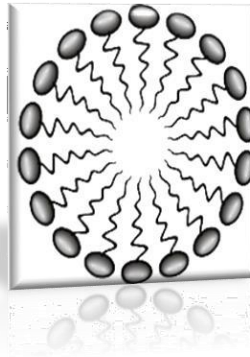
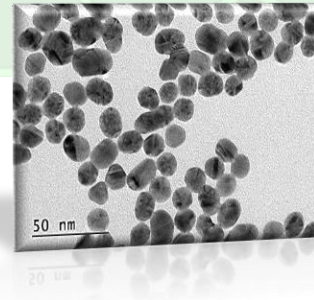

Micelle

Nanofiber

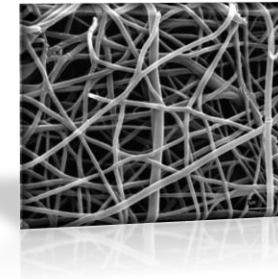

**Nanomaterials
(NMs)**

Nanoformulations

Nanoplate

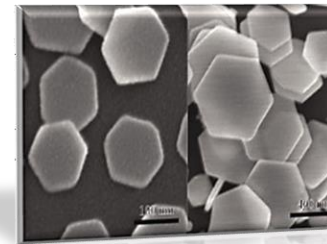

Nanocomposite

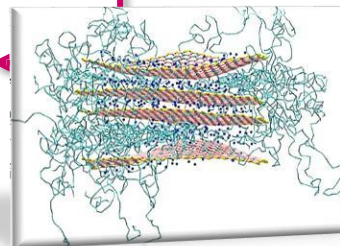

Nanotecnologie e nanomateriali nel mondo

INAIL



Entro il **2020** il **20%** circa di tutti i prodotti fabbricati nel mondo impiegheranno una certa quota di nanotecnologie (stima ILO, 2010)

I LAVORATORI NEL SETTORE

= 100.000

2008

400.000

Il tasso di crescita mondiale è stimato pari al **25% annuo**

2020 (stima ROCO M)

6 milioni



IL VALORE DEI NANOPRODOTTI

Dati in dollari americani (stima ROCO M)

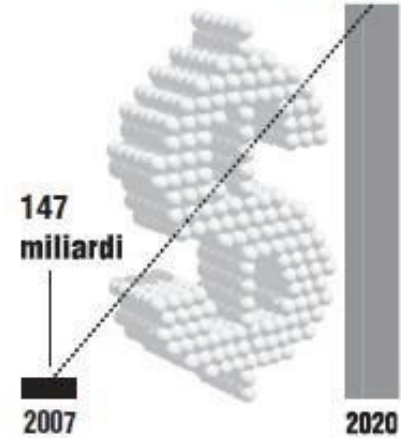

LA LORO DIFFUSIONE

Numero di prodotti nei quali si trovano nanomateriali (database del Woodrow Wilson Center)

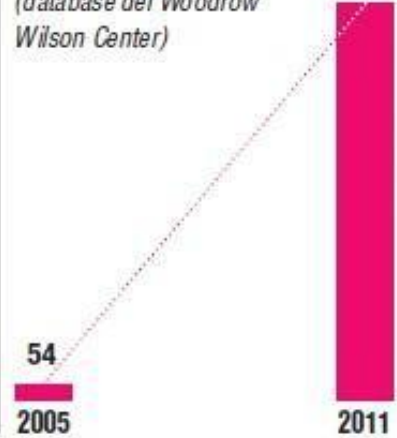

LE AREE DI UTILIZZO

- Salute e benessere
- Casa e giardino
- Cibo e bevande
- Automobile
- Elettronica e informatica
- Varie
- Elettrodomestici
- Prodotti per bambini

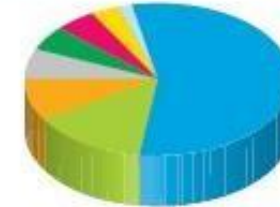

centimstri.it

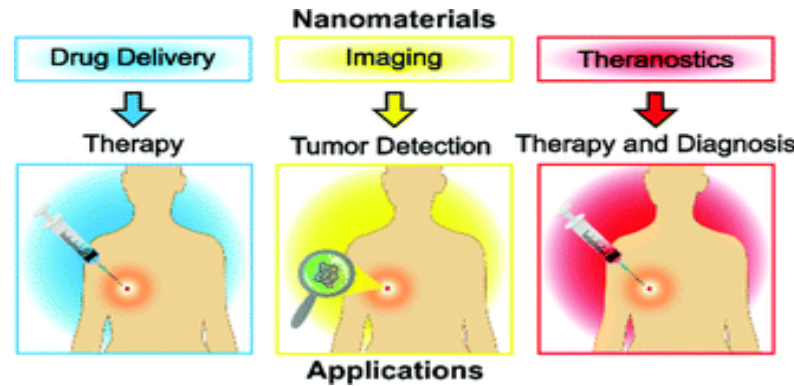

Nanomaterials for electrochemical sensors

- Metal Nanoparticles;
 - carbon nanotubes
 - graphene;
-
- Different properties with respect to micromaterial;
 - catalytic
 - High Surface/Volume;

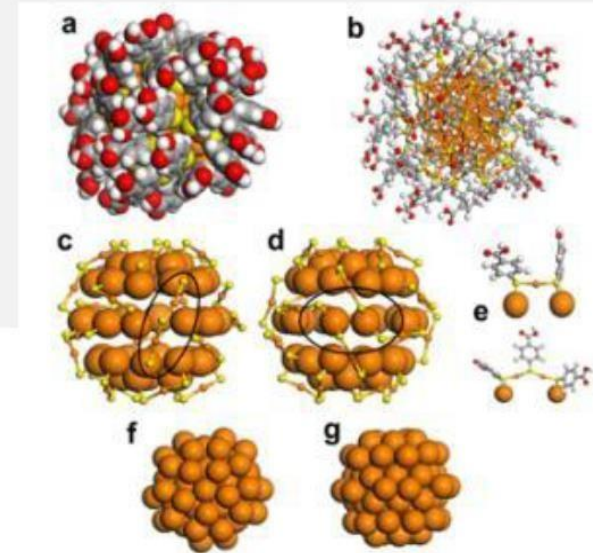
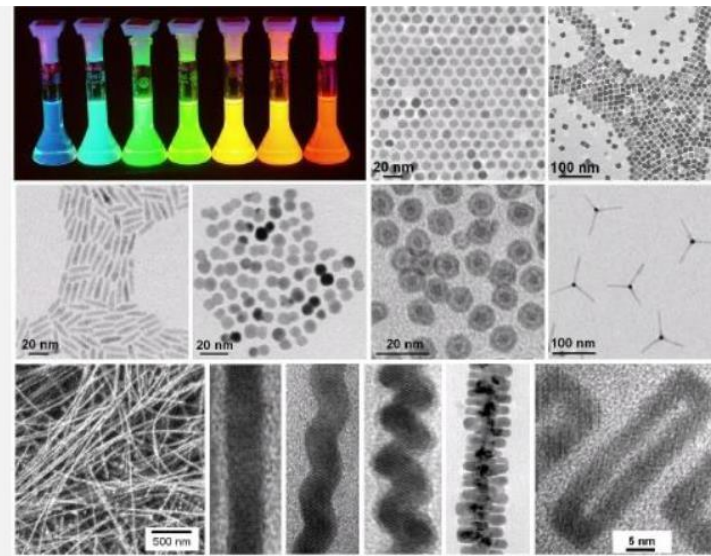

SWNT



MWNT

CARBON NANOTUBES

CHARACTERISTICS

- porous structure;
- high mechanical strength;
- easy to be modified;

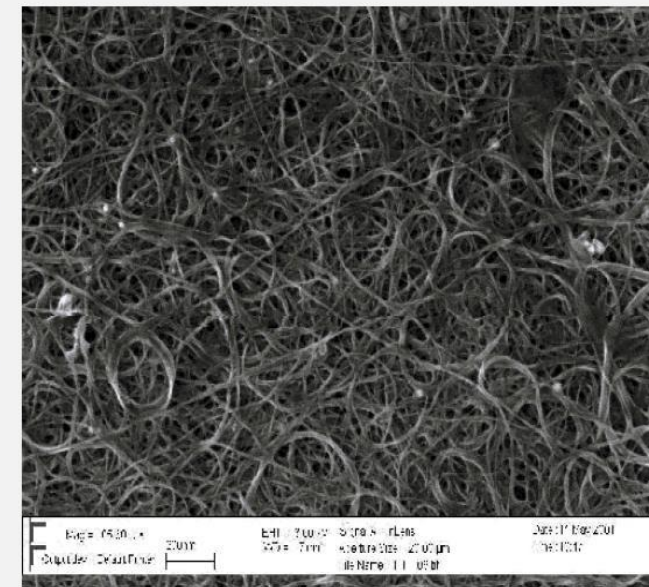
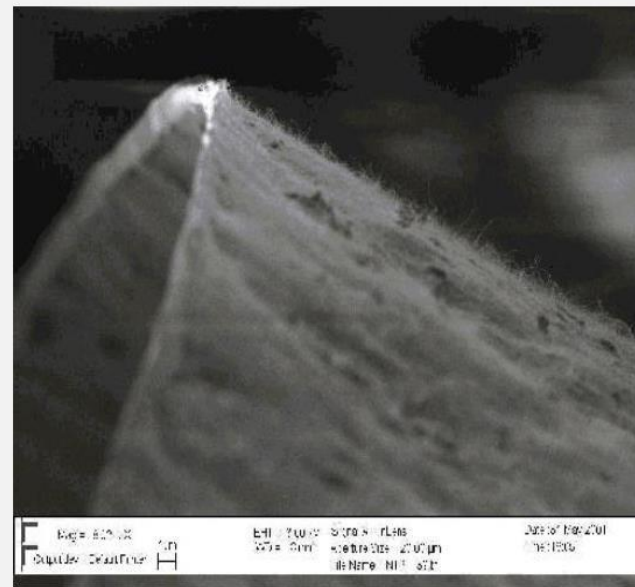
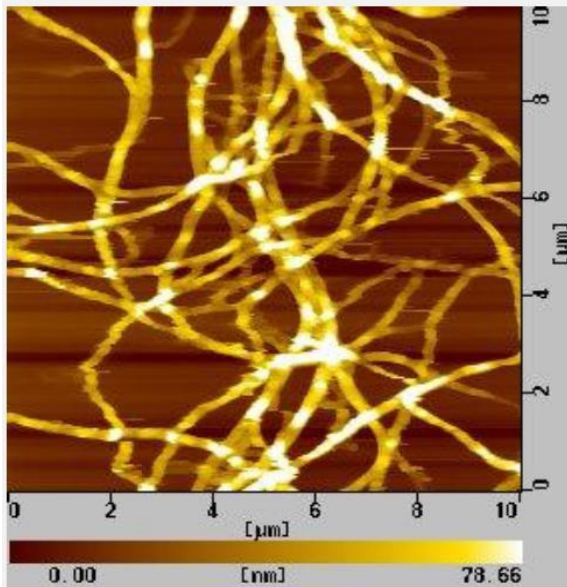
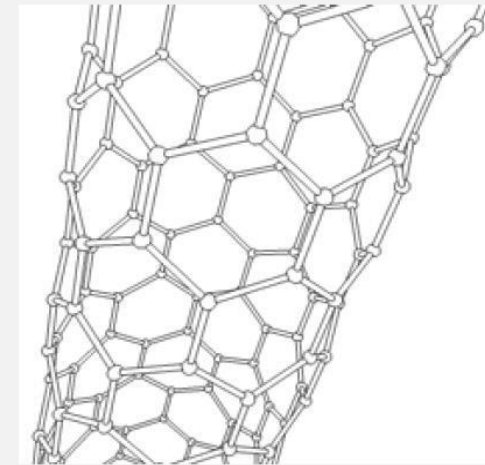
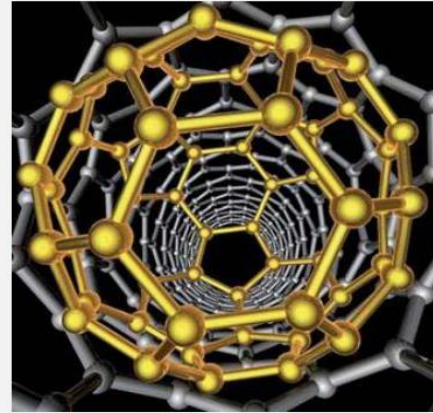

GRAPHENE: THE CARBON-BASED 'WONDER MATERIAL'

Since its discovery in 2003, graphene has been a hot topic in chemistry and materials science research. It's been linked with water purification, electronics, and biomedical applications. However, how close are we really to using graphene in our day-to-day lives? This graphic looks at its properties, uses, and future.

WHAT IS GRAPHENE?



SINGLE LAYER OF CARBON ATOMS

HONEYCOMB-LIKE STRUCTURE

GRAPHITE IS LAYERS OF GRAPHENE

ISOLATED IN 2003 IN MANCHESTER

Graphene is a single layer of graphite, the carbon-based material found in pencil leads. Graphite has been known for centuries, but graphene was only isolated in 2003, by shearing layers off of graphite using sellotape. It's a single atom-thick layer of carbon atoms, that are arranged in a flat, hexagonal lattice structure.

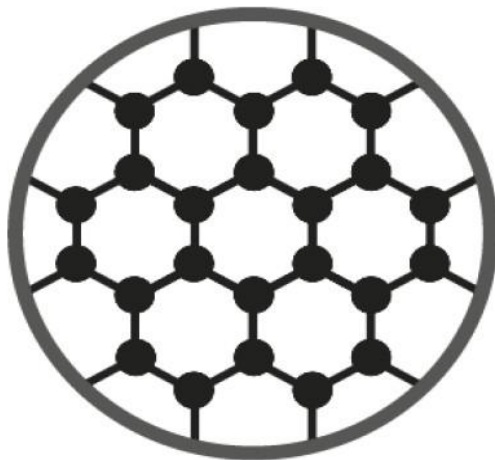

POTENTIAL USES OF GRAPHENE



TOUCH SCREENS IN DEVICES

Graphene's transparency and conductivity means that it can be used in displays and touchscreens. However, currently these are more expensive to produce than the currently used material, indium tin oxide.



WATER FILTRATION SYSTEMS

Graphene allows water to pass through it, but not other liquids and gases, so it can be used in water purification. Researchers are working on a device that could be capable of filtering salt from sea water.

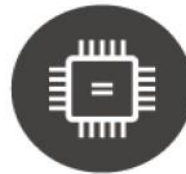

IN ELECTRONIC DEVICES

Graphene has been touted as silicon's successor, and has been used to make very fast transistors. However, its conductivity cannot be 'switched off' as silicon's can. Other 2D materials seem more promising.



MEDICAL SENSORS & DRUG DELIVERY

Several biomedical applications are being explored for graphene, including drug delivery, cancer therapy, and its use as a sensor. However, its toxicity profile must be investigated before any clinical uses.



ENERGY STORAGE & COMPOSITES

Graphene-based energy storage devices are possible. It can also substitute for graphite in normal batteries, improving efficiency. Additionally, it can be added to materials to make them stronger and more lightweight.

THE PROPERTIES OF GRAPHENE



HIGH ELECTRICAL
CONDUCTIVITY



200X STRONGER
THAN STEEL



THIN AND
LIGHTWEIGHT



HIGH THERMAL
CONDUCTIVITY



VERY HIGH
TRANSPARENCY

Graphene's 'wonder material' reputation stems from its superlative properties. It is a million times thinner than a piece of paper, yet stronger than diamond, and 200 times stronger than steel, due to the strong carbon-carbon bonds. It's also a flexible material, and conducts heat and electricity better than copper. Being only one atom thick, almost 98% of visible light passes through graphene, making it transparent.



Betalike

Sistema automatico per il controllo glicemico

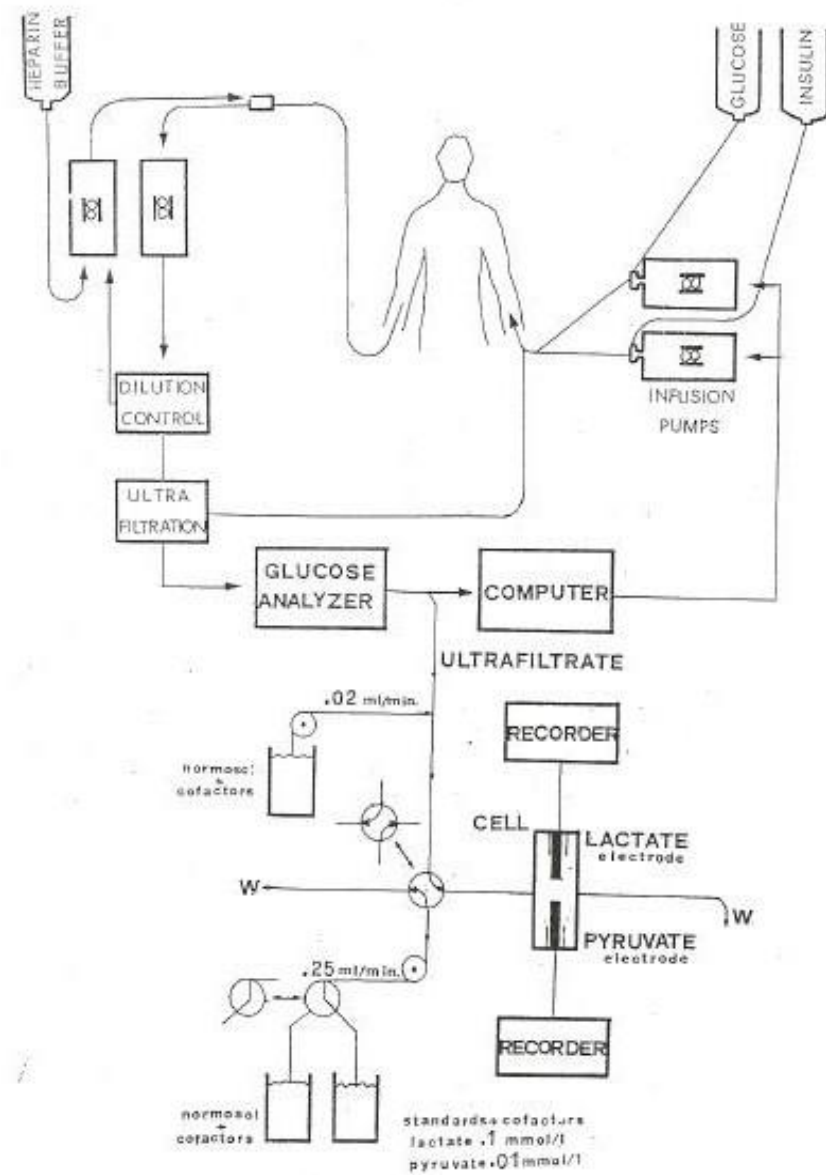

Microdialysis is a minimally-invasive sampling technique that is used for continuous measurement of free, unbound analyte concentrations in the extracellular fluid of virtually any tissue. Analytes may include endogenous molecules (e.g. neurotransmitter, hormones, glucose, etc.) to assess their biochemical functions in the body, or exogenous compounds (e.g. pharmaceuticals) to determine their distribution within the body. The microdialysis technique requires the insertion of a small microdialysis catheter (also referred to as microdialysis probe) into the tissue of interest. The microdialysis probe is designed to mimic a blood capillary and consists of a shaft with a semipermeable hollow fiber membrane at its tip, which is connected to inlet and outlet tubing. The probe is continuously perfused with an aqueous solution (perfusate) that closely resembles the (ionic) composition of the surrounding tissue fluid at a low flow rate of approximately 0.1-5 $\mu\text{L}/\text{min}$. Once inserted into the tissue or (body)fluid of interest, small solutes can cross the semipermeable membrane by passive diffusion. The direction of the analyte flow is determined by the respective concentration gradient and allows the usage of microdialysis probes as sampling as well as delivery tools. The solution leaving the probe (dialysate) is collected at certain time intervals for analysis. (source Wikipedia)

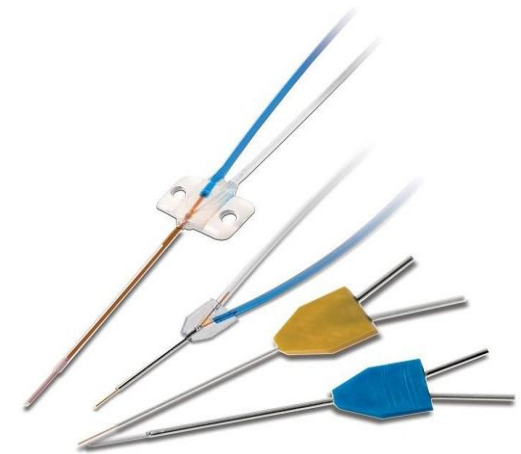

FEATURE OF MICRODIALYSIS

- The perfusion system is simple: due to the presence of a membrane, the probe is a closed liquid system and the flow is unidirectional.
- It makes it possible to sample continuously for hours or days.
- It can be used to recover and/or introduce substances in the medium.
- It collects a representative sample of all substances in the analysed medium.
- The size of the perfused area can be regulated by varying the length of the membrane.
- The membrane excludes large molecules such as proteins and enzymes, i.e. purifies the sample so that it is possible to introduce it directly into the analytical instrument.
- It is possible to monitor multiple analytes by coupling other analytical techniques to the microdialysis system.

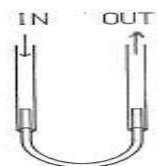

MICRODIALYSIS
HOLLOW FIBER
(DIAM. 200 μm)

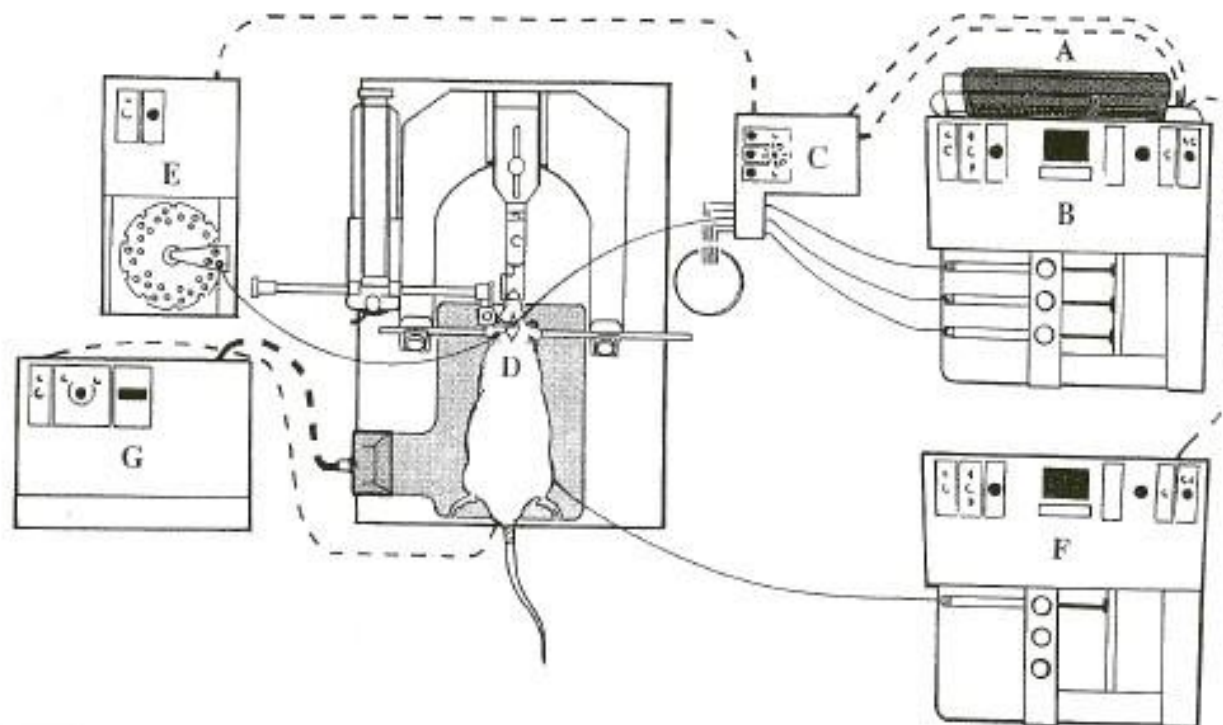
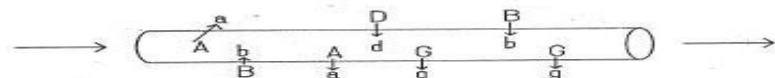
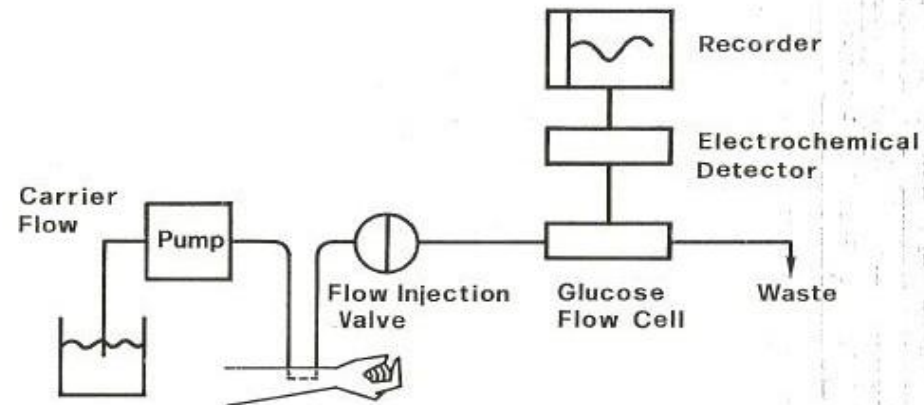

Fig. 2. Schematic drawing of the instruments used during a microdialysis experiment on a rat. A = computer controlling the experiment. B = perfusion pump with three syringes containing different perfusion fluids. C = syringe selector which selects one of the syringes of the pump (B) under computer control (A). D = anaesthetized rat in a stereotaxic instrument. The microdialysis probe is held in the instrument and placed in the brain. E = microfraction collector, which collects fractions under the control of the computer (A) or the pump (B). F = second pump used to inject a drug systemically under the control of the computer (A). G = temperature controller to maintain the anaesthetized animal at the correct temperature.

CARATTERISTICHE DI UN SENSORE PER LA MISURA "IN VIVO"

- essere biocompatibile;
- mostrare stabilità di risposta per tutto il tempo della misura (che può essere anche 24 ore o più);
- misurare in un range di concentrazione pari al range fisiologico sia in condizioni normali che soprattutto patologiche;
- essere miniaturizzabile, in modo che la sua inserzione "in vivo" e la sua permanenza non siano dolorose;
- non risentire della presenza di sostanze interferenti presenti nei fluidi biologici, che non possono essere eliminate.



Calibration curves of lactate using different microdialysis fibers
Flow rate 30 μ l /min

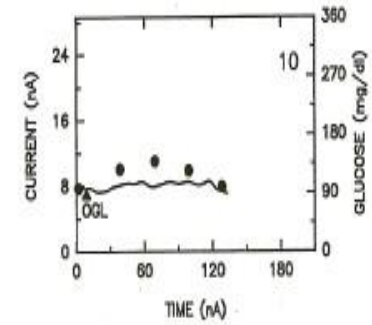
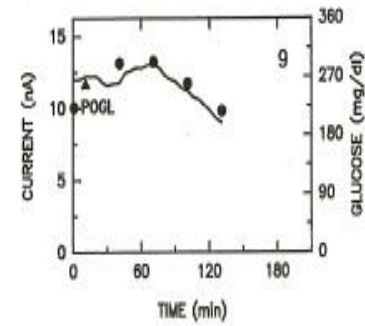
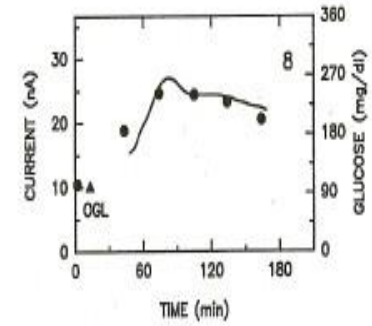
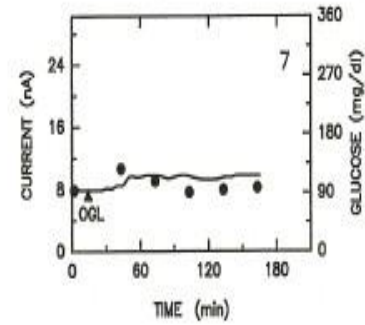
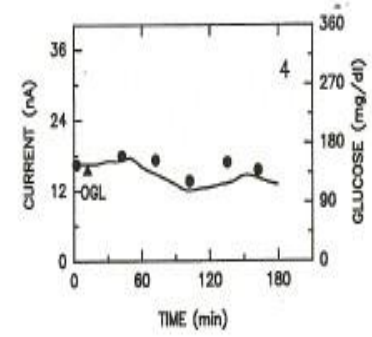
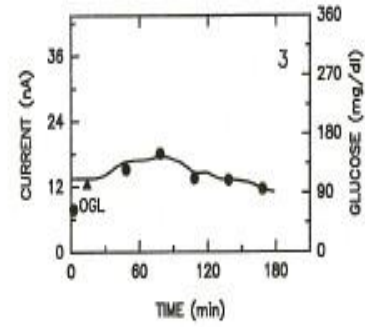
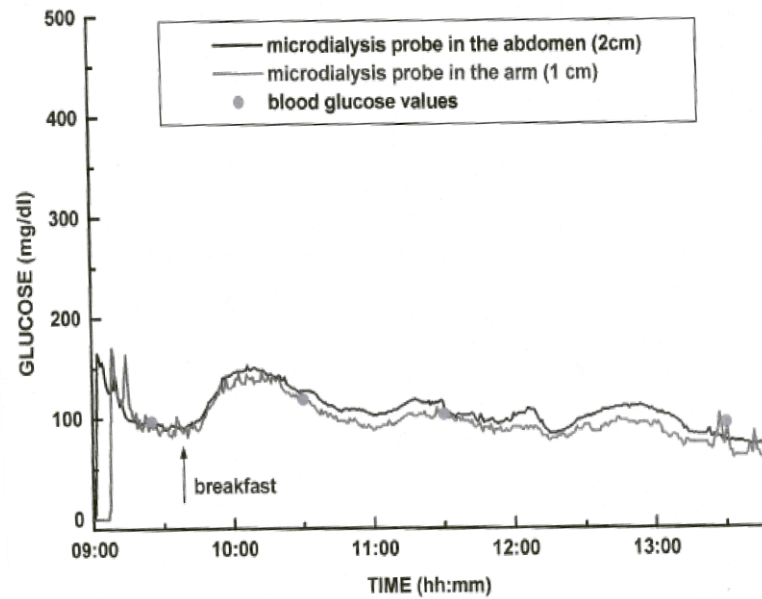
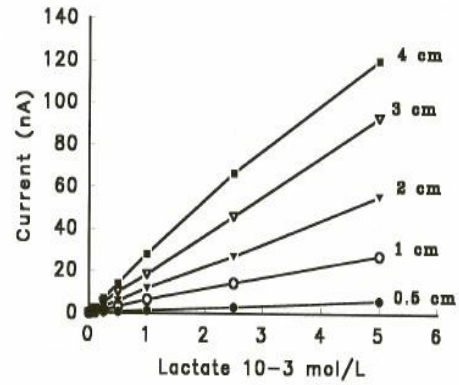



GlucoDay® S è uno strumento innovativo, sviluppato dalla ricerca Menarini, per il monitoraggio continuo sottocutaneo del glucosio, per un periodo di 48 ore, nei pazienti umani.

GlucoDay® S nel mondo è il primo strumento basato sulla tecnica della "microdialisi" ad avere ottenuto la marcatura CE ai sensi della Direttiva sui Dispositivi Medici, la quale è indispensabile per la commercializzazione di un prodotto nell'ambito dell'Unione Europea.

GlucoDay® S è un dispositivo professionale che deve essere utilizzato solo da personale medico qualificato e addestrato e che è stato specificamente progettato per indagini cliniche o diagnostiche sui pazienti. **GlucoDay® S** è classificato come Dispositivo Medico, Classe IIA.

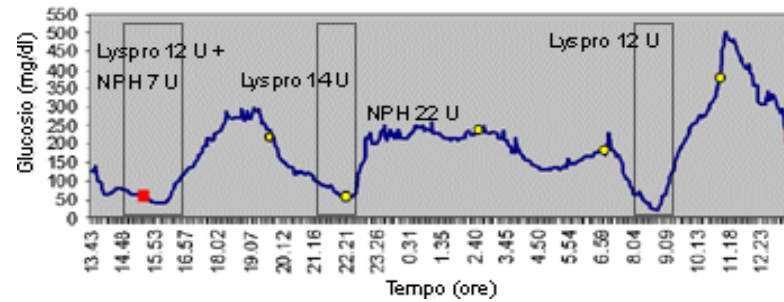

In questo giovane paziente diabetico sono stati rilevati 3 episodi di ipoglicemia post-prandiale (dopo pranzo, cena e colazione), come potete vedere in questo profilo. Le misure della glicemia con sangue venoso sono rappresentate in rosso, quelle con sangue capillare sono rappresentate in giallo.



In questo paziente con DM1 **GlucoDay® S** ha rivelato un episodio di ipoglicemia prolungata durante la notte.

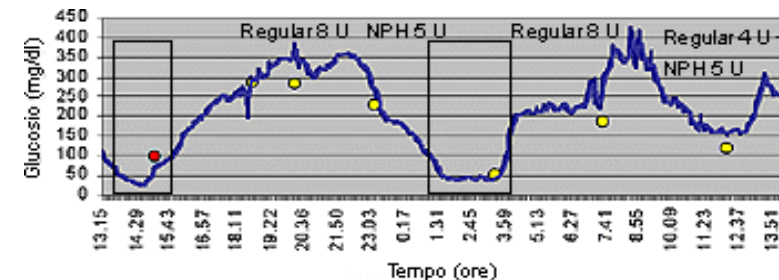

Enzyme-Based Glucose Sensor: From Invasive to Wearable Device

Hyunjae Lee, Yongseok Joseph Hong, Seungmin Baik, Taeghwan Hyeon,
and Dae-Hyeong Kim**

Concentration range of glucose:

$2\text{--}40 \times 10^{-3}$ M in blood,

$1.99\text{--}22.2 \times 10^{-3}$ M in interstitial fluid (ISF)

$0.008\text{--}1.77 \times 10^{-3}$ M in saliva

$0.01\text{--}1.11 \times 10^{-3}$ M in sweat

$0.05\text{--}5 \times 10^{-3}$ M in tears

Invasive methods

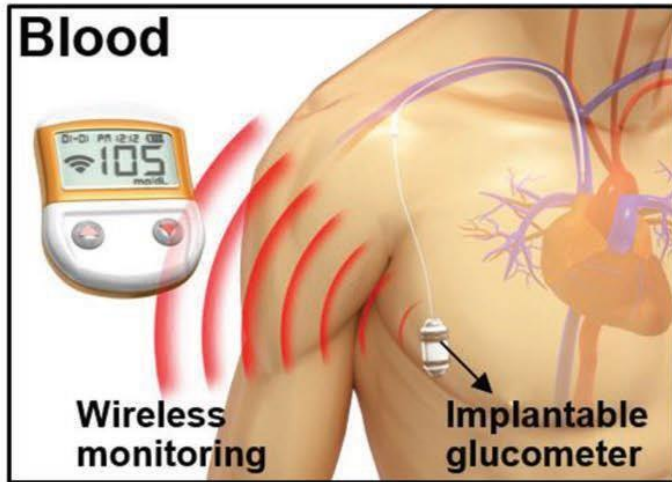
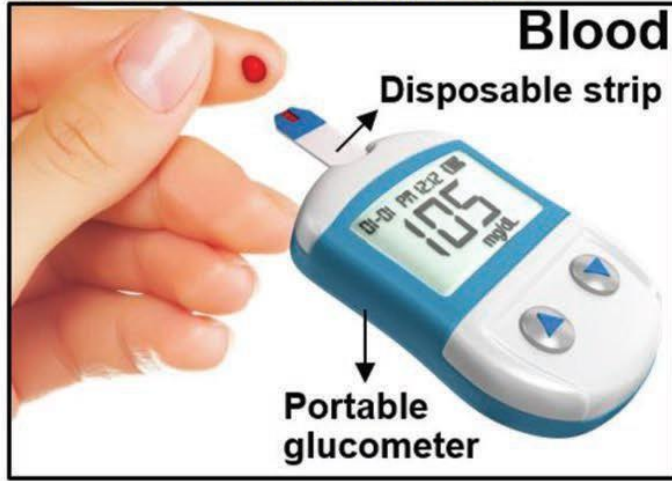

Noninvasive methods

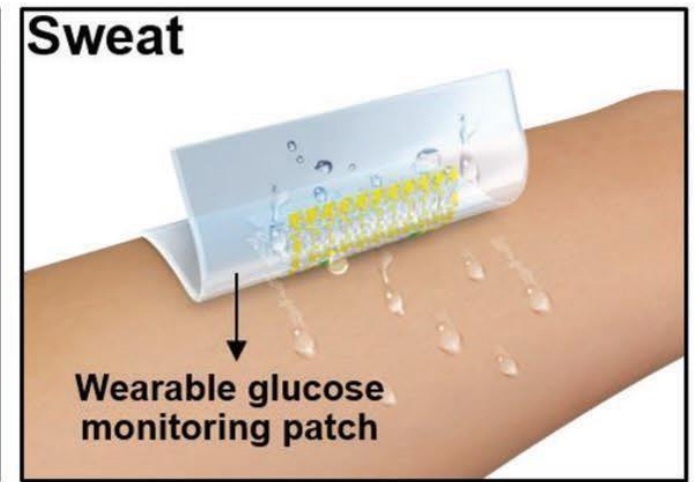
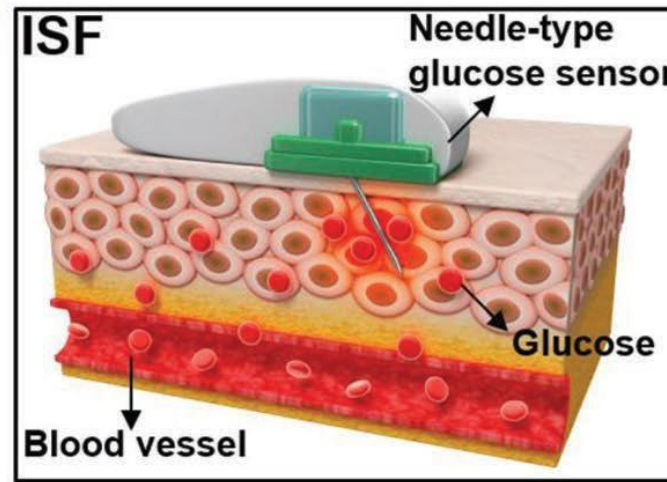
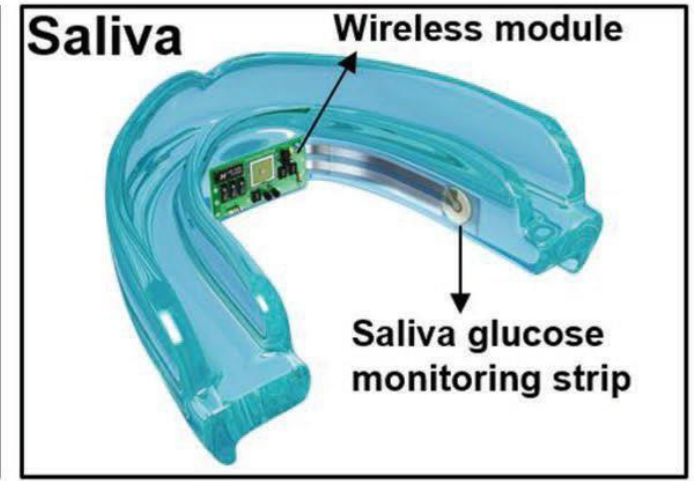
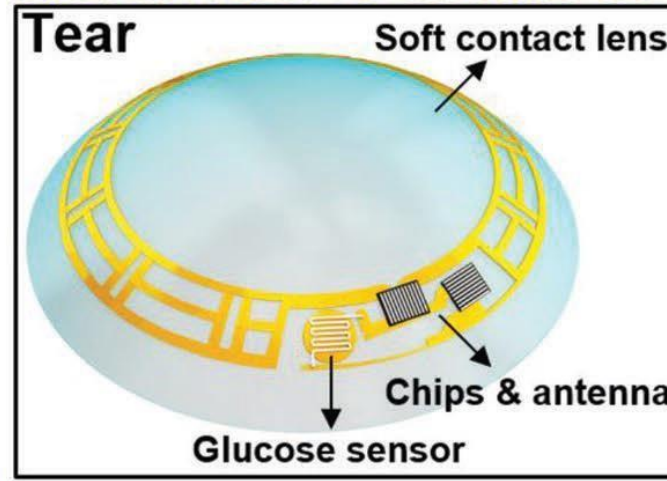

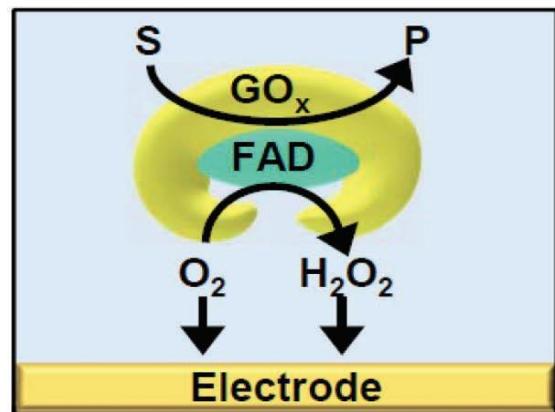
a 1st Generation

&

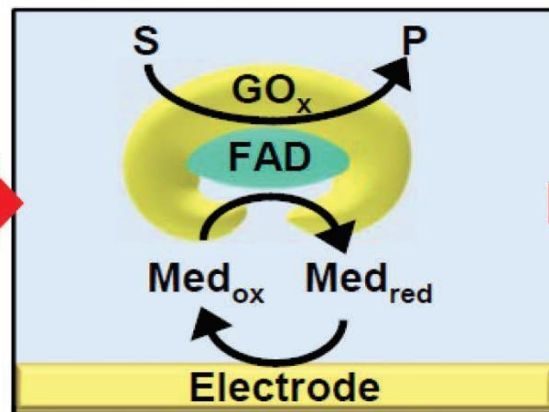
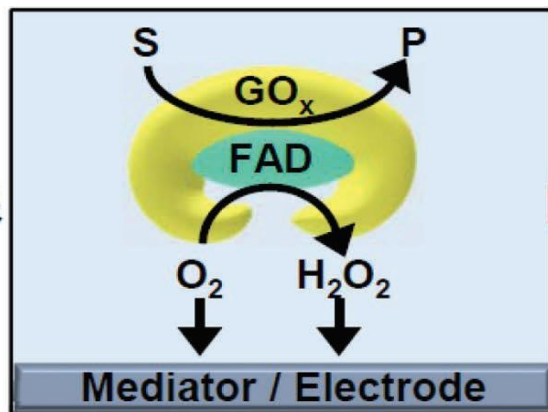
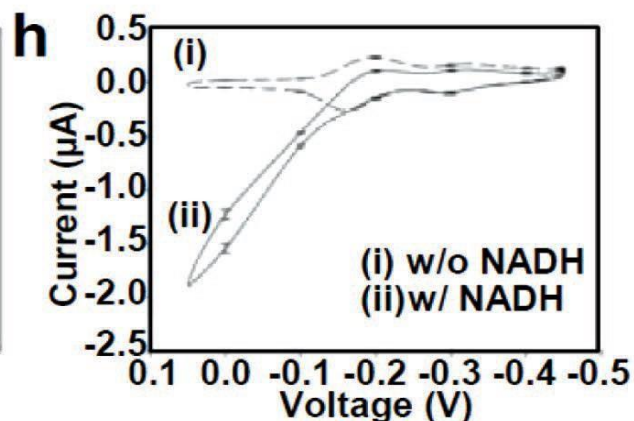
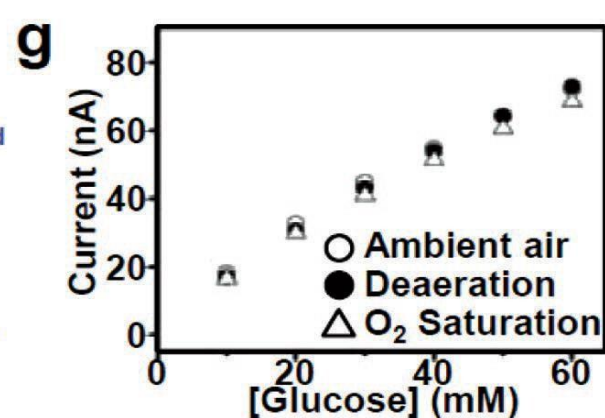
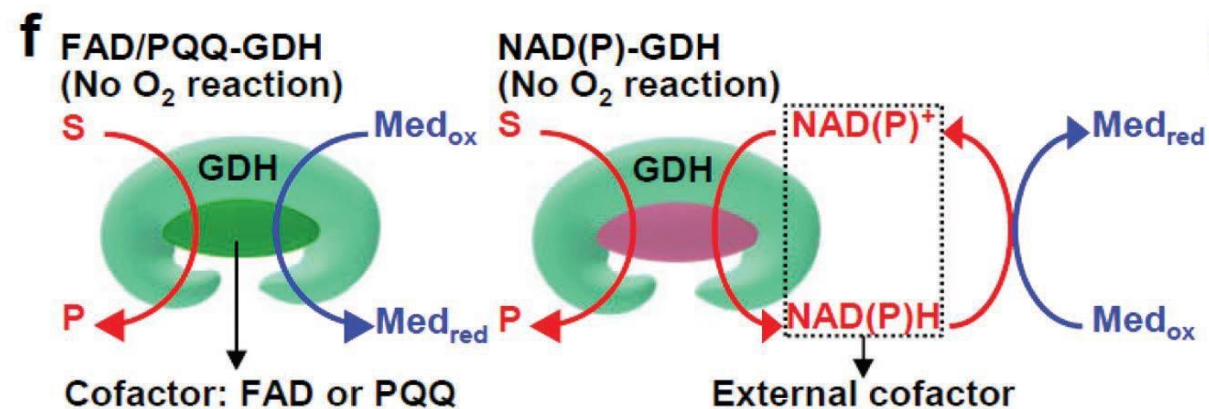
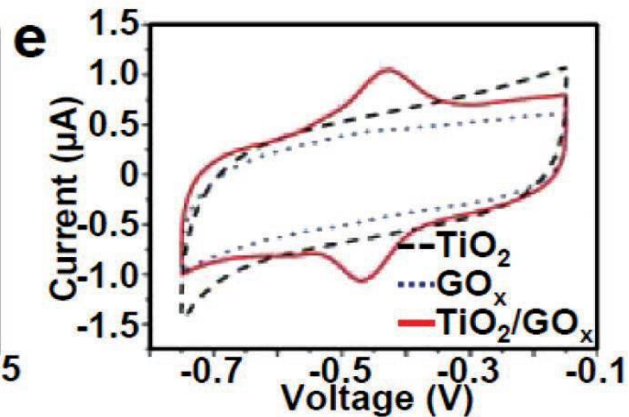
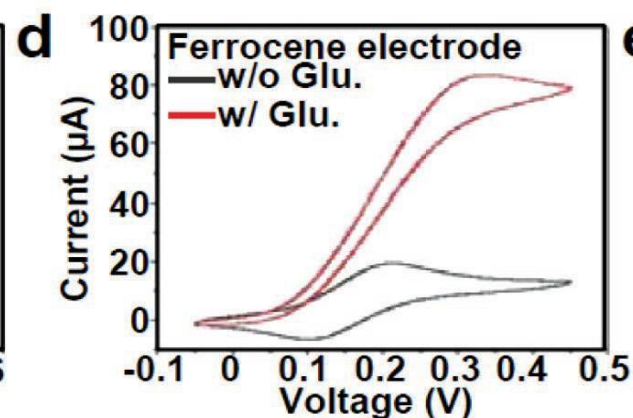
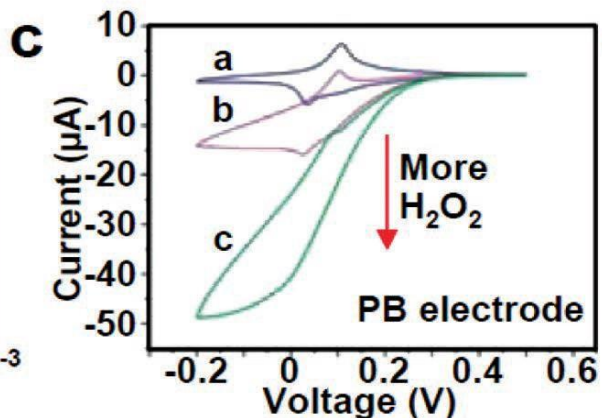
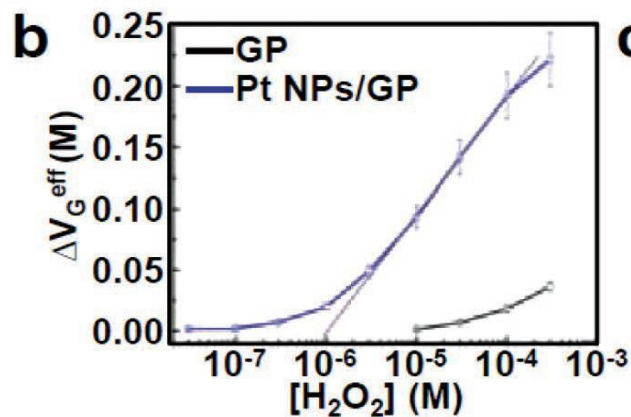
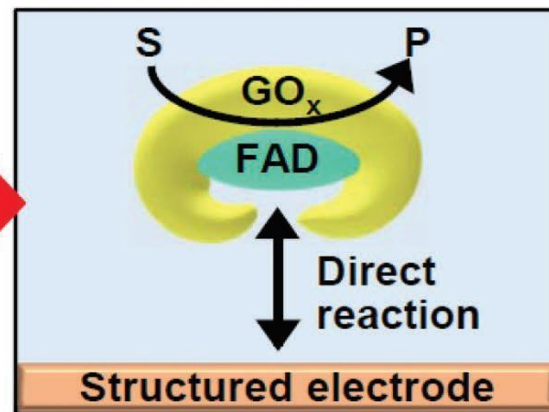
2nd Generation3rd Generation

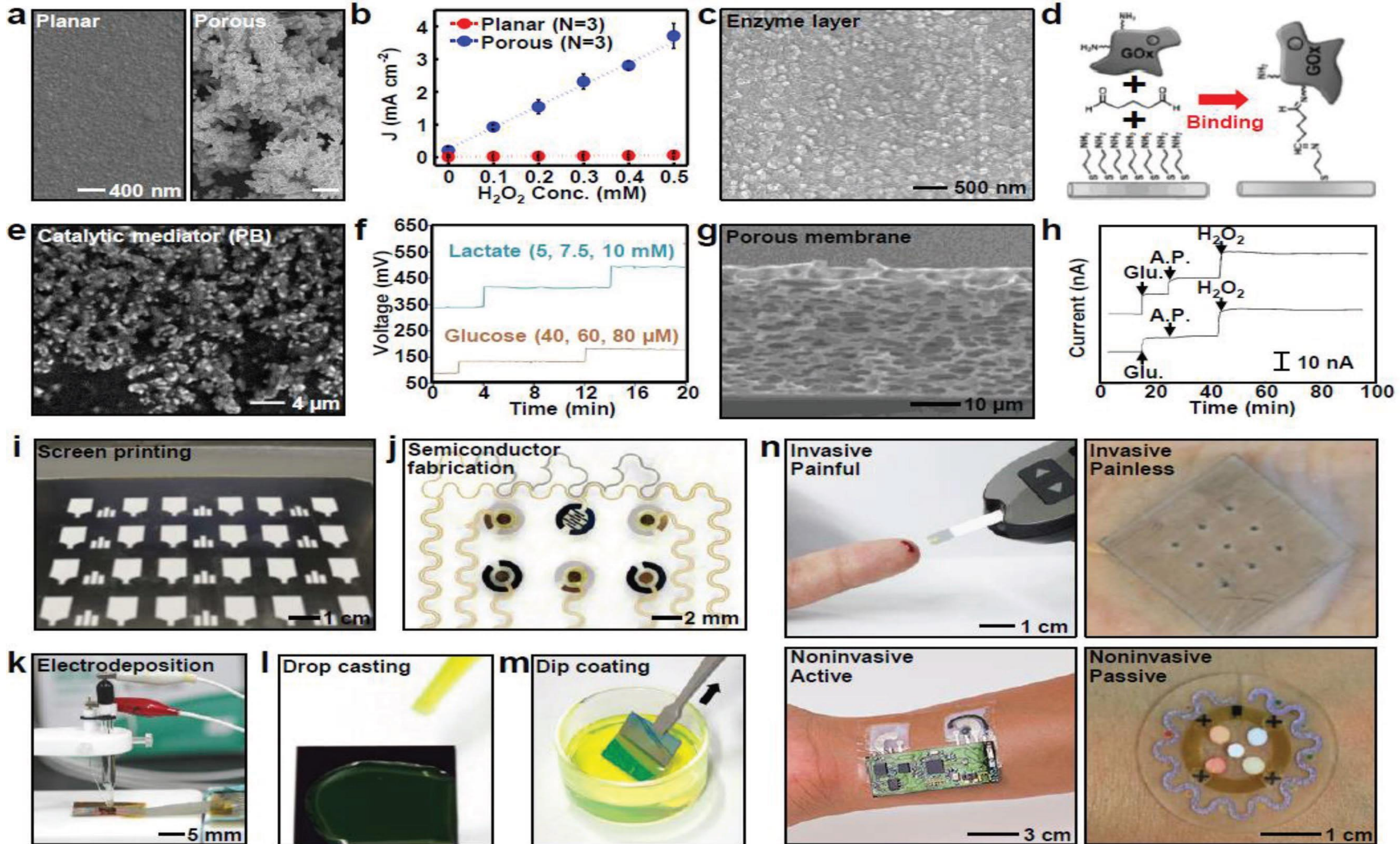

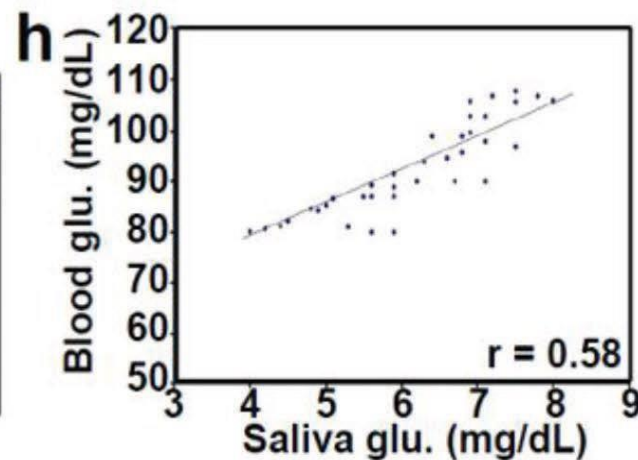
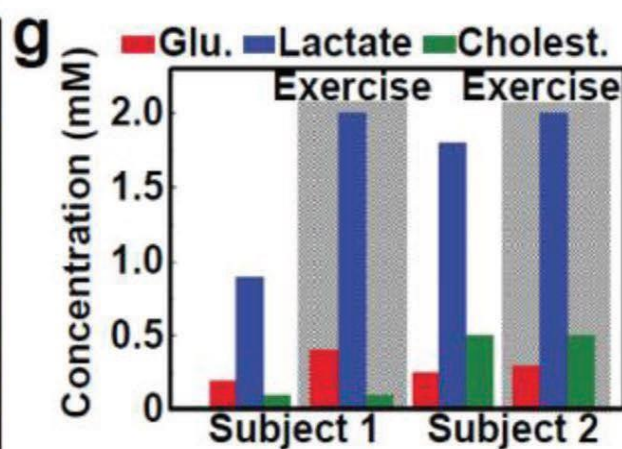
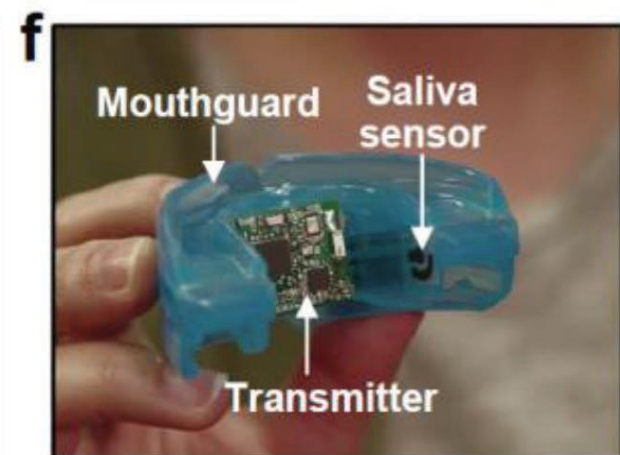
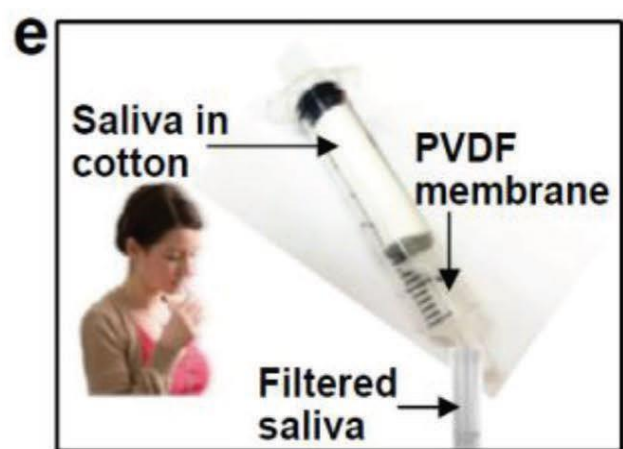
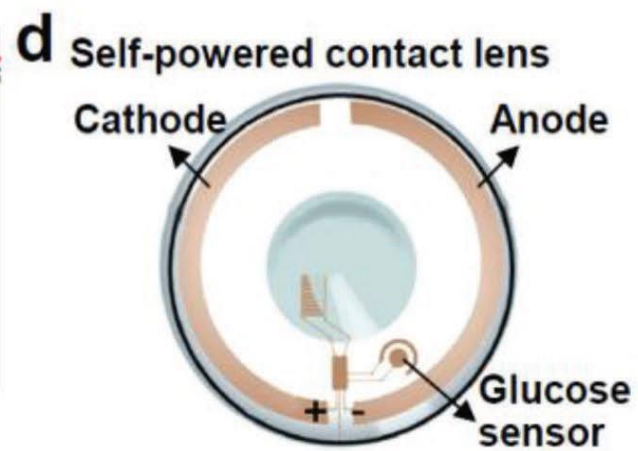
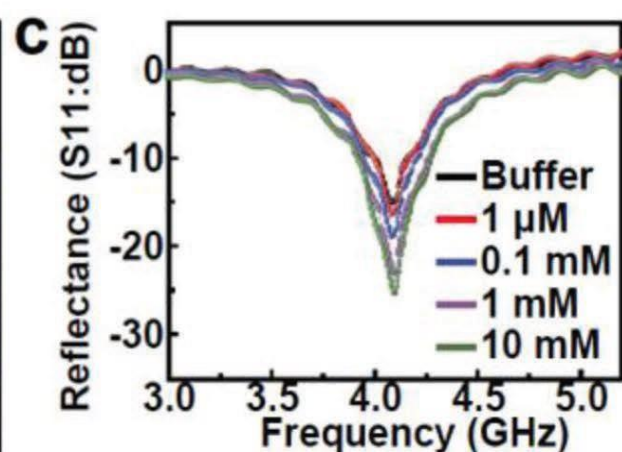
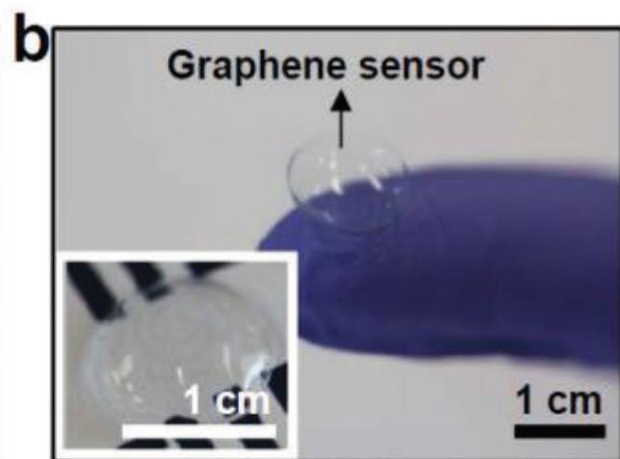
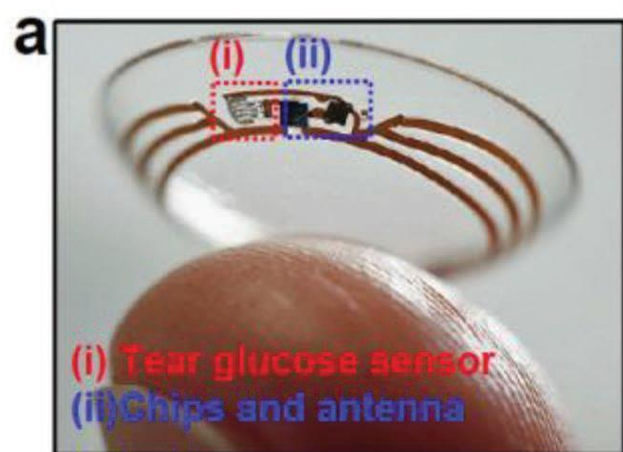

Oxidative stress

Redox homeostasis plays a key role in cell physiology; in normal conditions cells maintain this status through the interaction and interconversion of redox active molecules. The most representative groups of molecules involved in the process are the Reactive Oxygen Species (ROS) and Reactive Nitrogen Species (RNS). ROS are produced intracellularly during aerobic metabolism and includes superoxide, hydrogen peroxide and hydroxyl radical . RNS includes nitric oxide (NO) and related compounds as peroxynitrite ONOO and nitrite NO₂. Low concentrations of ROS have been proved to stimulate the maintenance of the redox balance in cellular processes whereas high concentrations are able to cause the so-called oxidative stress. Oxidative stress is a very general concept that has been defined by Sies as “An imbalance between oxidants and antioxidants in favor of the oxidants, leading to a disruption of redox signaling and control and/or molecular damage” . Aerobic cells are known to continuously produce superoxide ions during aerobic metabolism as a side product during their metabolism. This molecule is highly reactive, and it is readily eliminated by fast disproportionation into H₂O₂ and O₂, with an estimated half-life of 5 s at physiological pH. However, the high intracellular activity of the superoxide dismutase (SOD) keeps the physiological concentrations of superoxide in the range of few pM . SOD can convert superoxide into H₂O₂, a much more stable product. In fact, it is considered as more powerful cytotoxic agent since the extended half-life allow diffusion in the whole cell and extracellular space, acting as source of hydroxyl radical's through the Fenton Reaction (FR). Hydroxyl radicals are among the most powerful hydrogen acceptors, being able to damage cellular components. Living cells possess the ability to scavenge H₂O₂ by catalase (CAT), which catalyzes the disproportionation into O₂ and H₂O. This mechanism allows to maintain a steady state concentration of H₂O₂ in the range of few nM. However, CAT suffers from substrate inhibition, creating a quite efficient mechanism at the physiological levels but leaving cells unprotected when H₂O₂ concentrations raises. Cells can change the metabolism under xenobiotics exposure and produce high quantities of radical oxygen by NADPH oxidase activation. This physiological response is also accompanied by the activation NO-synthases that produces NO; this can react with O₂ forming NO₂⁻, but also with the primary oxygen radical giving rise to another highly oxidant specie, peroxynitrite (ONOO⁻).

H₂O₂ electrochemical detection as oxidative stress marker

Objective

H₂O₂ electrochemical sensing in a Parkinson's disease cellular model

Oxidative stress on-chip

What is Oxidative Stress?

“An imbalance between oxidants and anti-oxidants in favor of the oxidants, leading to a disruption of redox signaling and control and/or molecular damage”

*Sies, H. (2015) 'Oxidative stress: a concept in redox biology and medicine', Redox Biology, 4, pp. 180–183.

Several ROS and RNS are involved in OS. Why detecting H₂O₂?

- ✓ Relatively stable
- ✓ Able to diffuse extracellularly
- ✓ Can produce highly cytotoxic OH· by the Fenton Reaction

Limitations of common electrodes (Cu, Pt, Au...) in H₂O₂ electrochemical sensing

- Poor selectivity
- Low sensitivity
- Challenging coupling to cell



Prussian Blue

- ✓ Highly sensitivity H₂O₂
- ✓ Highly selective

Lab-on-a-chip

- ✓ Suitable coupling with electrochemical sensors
- ✓ Potential application for cell culturing

Limitations: complex clean room-based fabrication methods

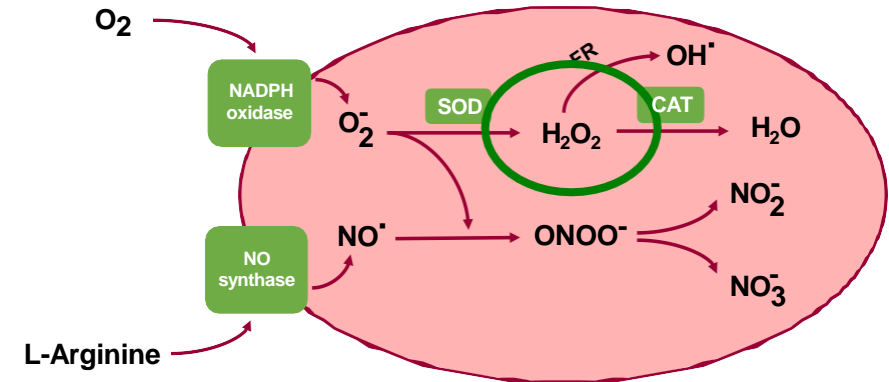

H₂O₂ electrochemical detection as oxidative stress marker

Objective

H₂O₂ electrochemical sensing in a Parkinson's disease cellular model

Oxidative stress on-chip

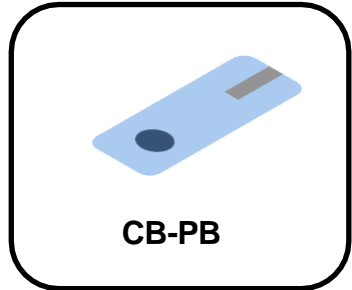

Electrochemical characterization

Improved H₂O₂ sensitivity

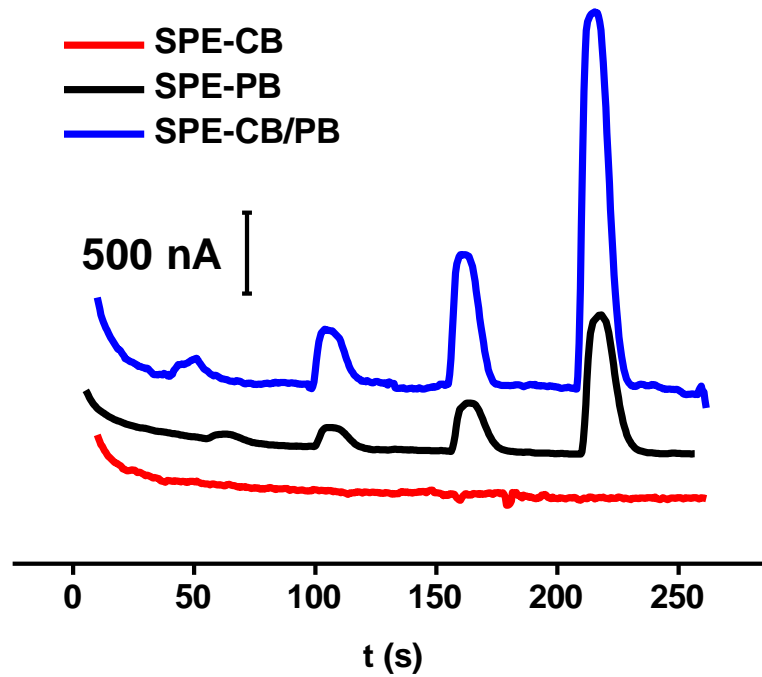

H₂O₂ selectivity

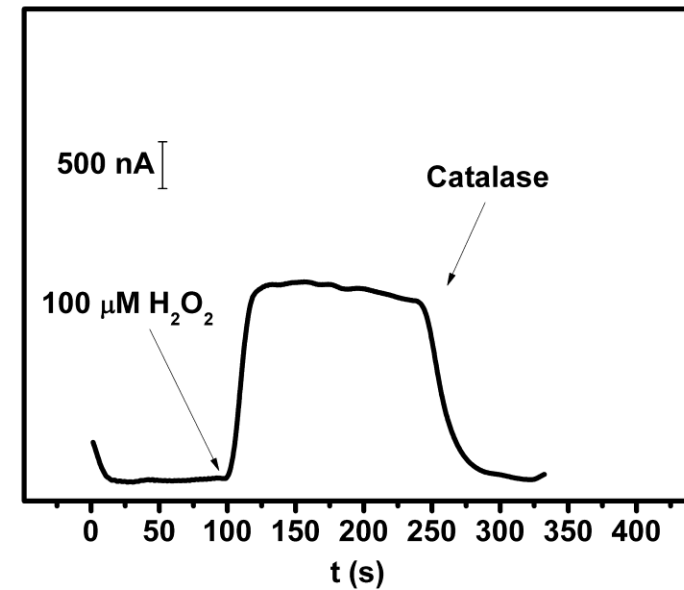

H₂O₂ electrochemical detection as oxidative stress marker

Objective

H₂O₂ electrochemical sensing in a Parkinson's disease cellular model

Oxidative stress on-chip

Application to neuroblastoma SH-SY5Y cells as Parkinson's disease model

Experimental set-up

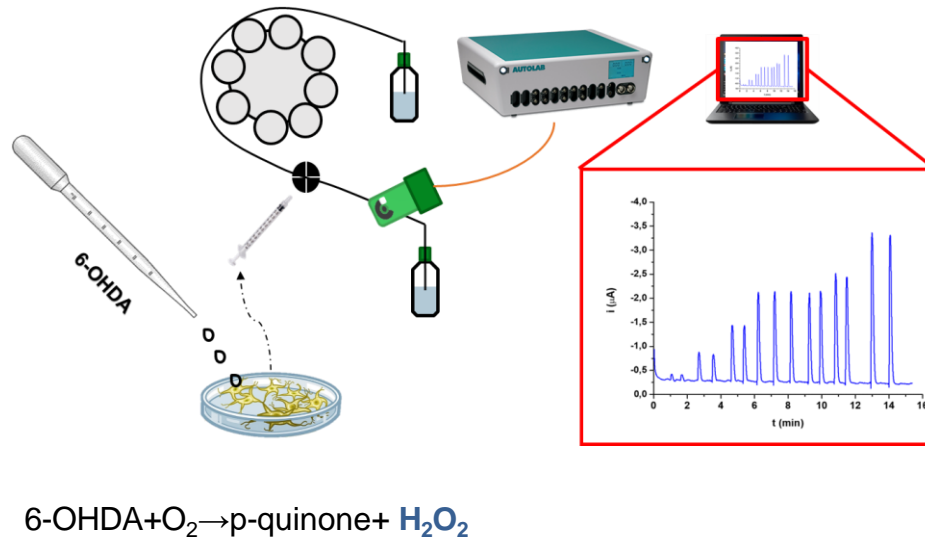

H₂O₂ concentrations vs. Cell viability

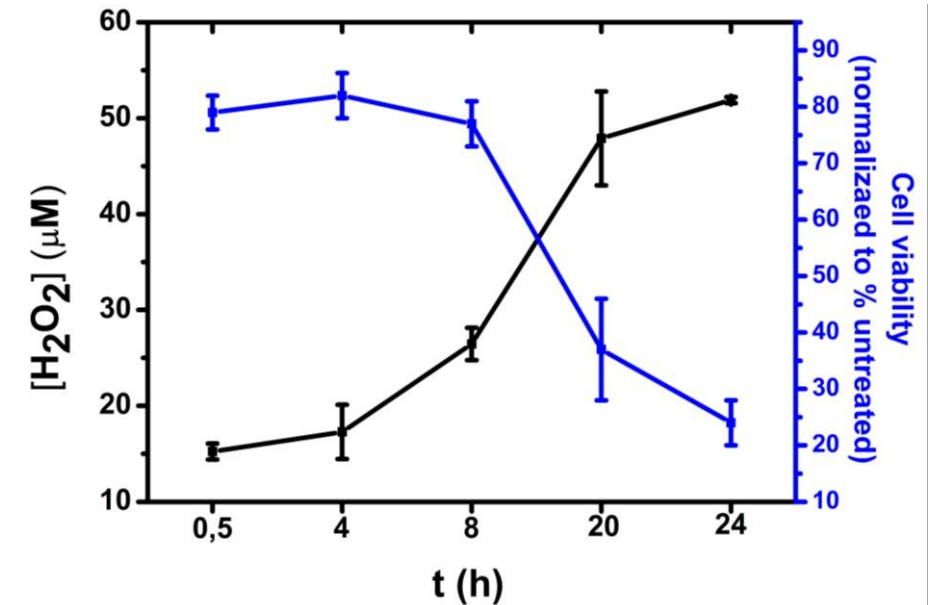

H₂O₂ electrochemical detection as oxidative stress marker

Objective

H₂O₂ electrochemical sensing in a Parkinson's disease cellular model

Oxidative stress on-chip

Prussian Blue-based electrode array for in-situ detection of H₂O₂ released by HeLa cells

Cell culturing



H₂O₂ sensing



Effect of PPs on oxidative stress

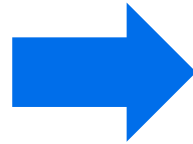

Low-cost fabricated LoC

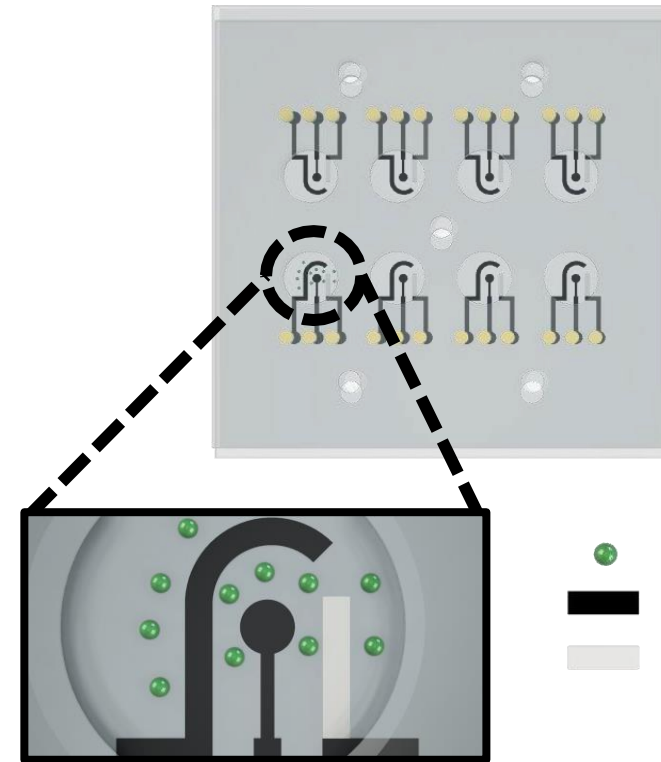

- HeLa cells
- PB-based electrodes
- Ag/AgCl electrodes

H₂O₂ electrochemical detection as oxidative stress marker

Objective

H₂O₂ electrochemical sensing in a Parkinson's disease cellular model

Oxidative stress on-chip

Adhesive vinyl



Laminating pouches

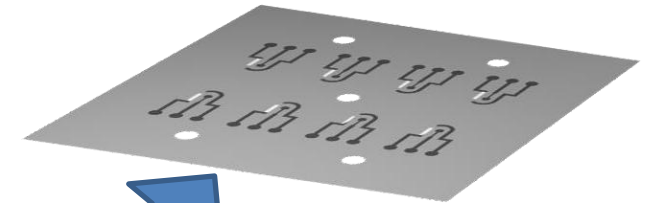

Computer assisted design
Adhesive vinyl stencil stuck
on a PET/EVA base layer

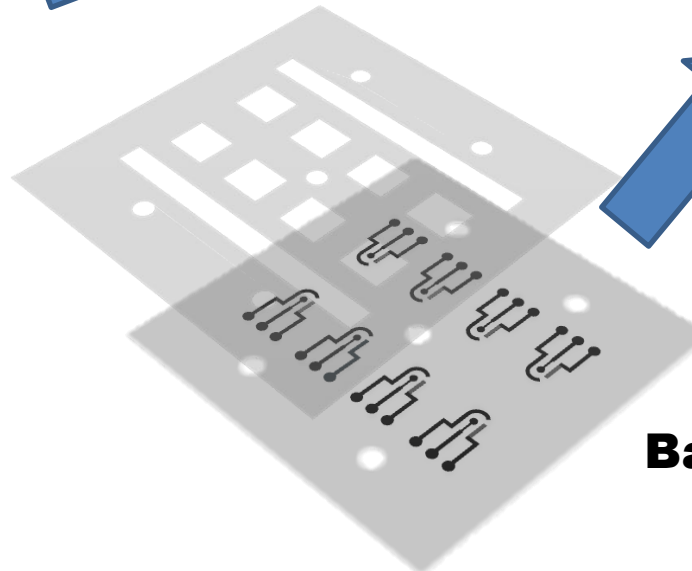
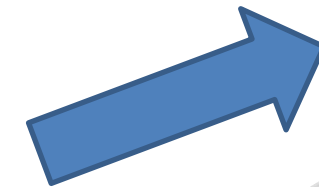

Base layer

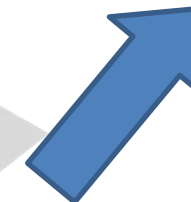

Prussian Blue
electrode array
(PBEA)

Thermal
lamination of
isolating layer
over the base
layer

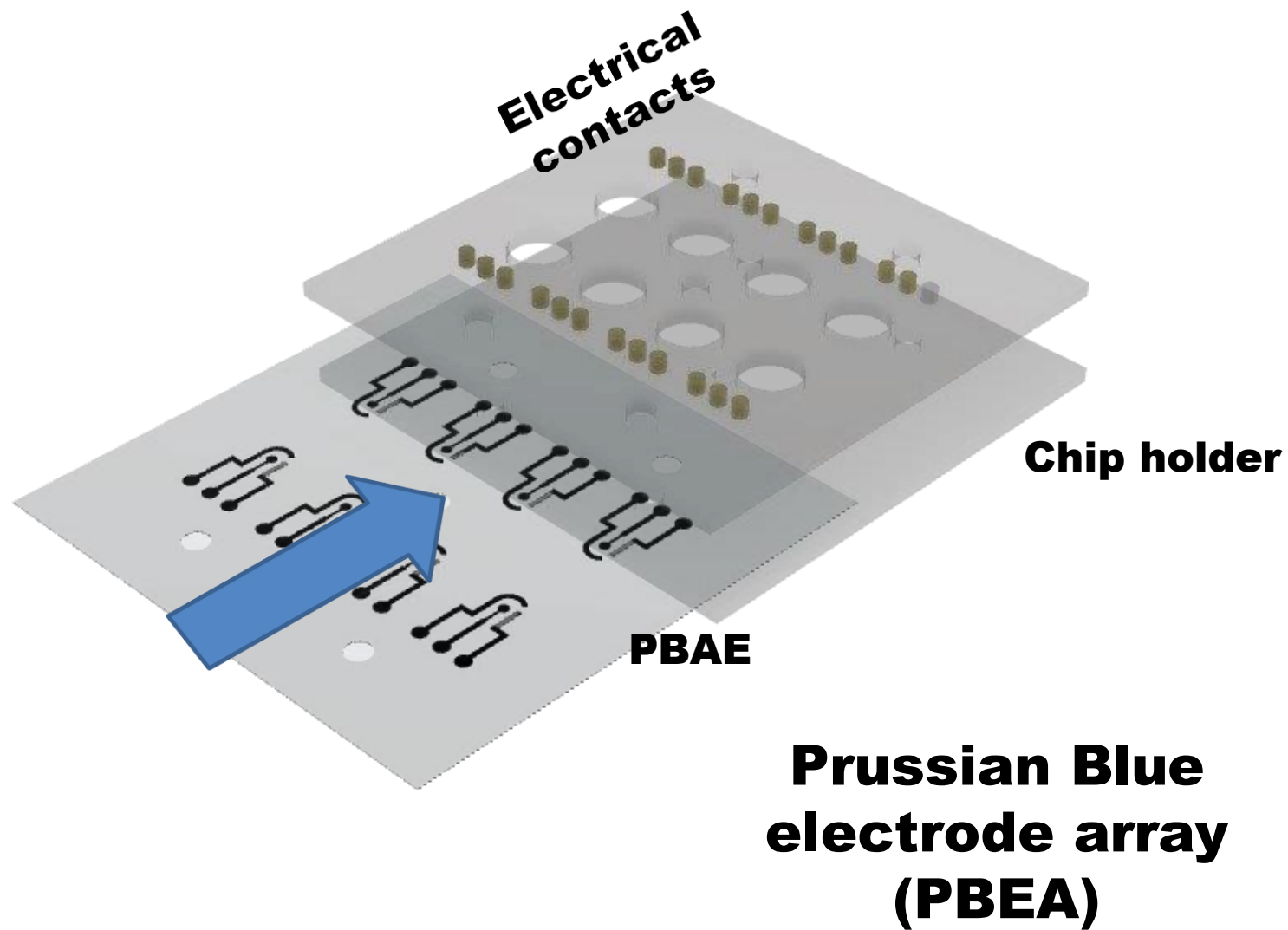
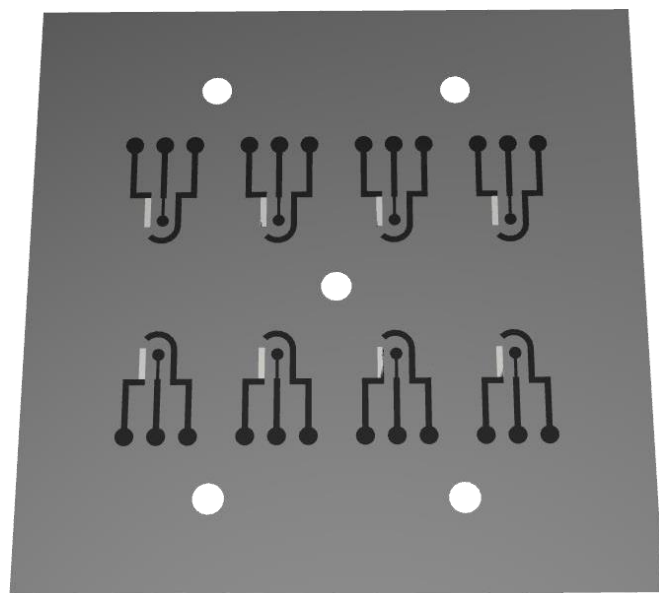

H₂O₂ electrochemical detection as oxidative stress marker

Objective

H₂O₂ electrochemical sensing in a Parkinson's disease cellular model

Oxidative stress on-chip

Signals from HeLa cell culture stimulated H₂O₂ release using N-Formylmethionine-leucyl-phenylalanine (fMLP)

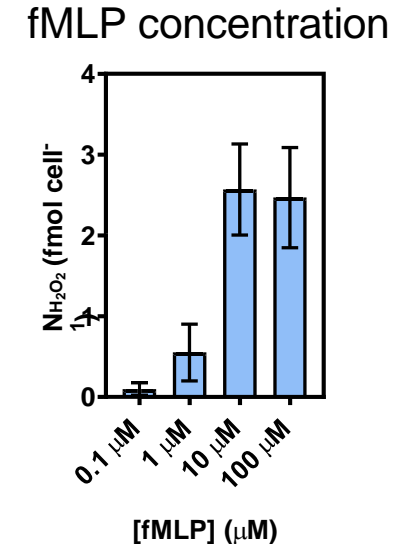
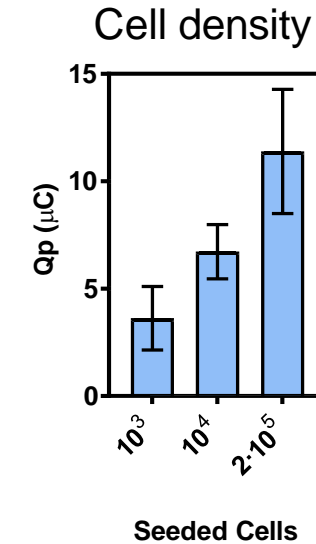
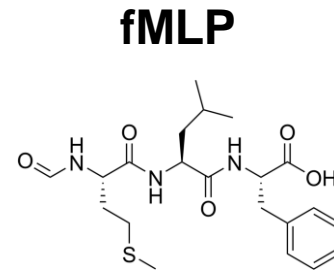
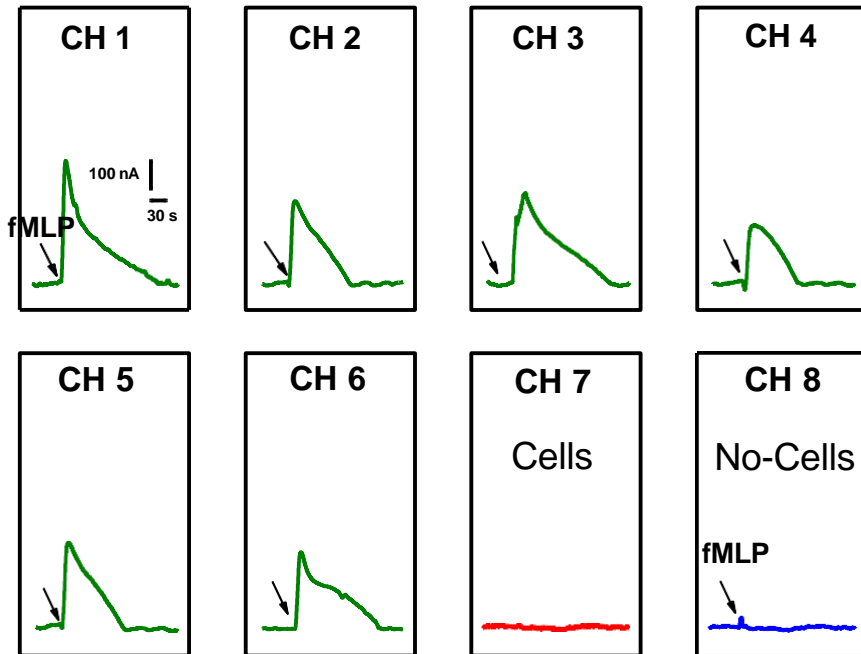

Cocoa extracts effect

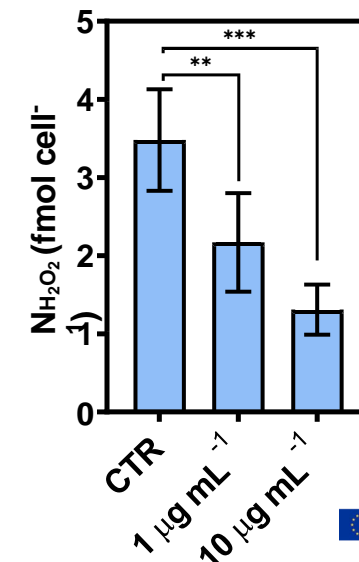

D. Rojas, J.F. Hernández-Rodríguez, F. Della Pelle, M. del Carlo, D. Compagnone, A. Escarpa. Biosen. Bioelectron. 170 (2020) 112669.

Paper as substrate



Paper can...

Store

Filter

React

Drawbacks...

Reagents diffusion...

Electrical noise! ☹️

An hydrophobic

barrier

is needed...

From Paper to E-Paper

Few and easy steps

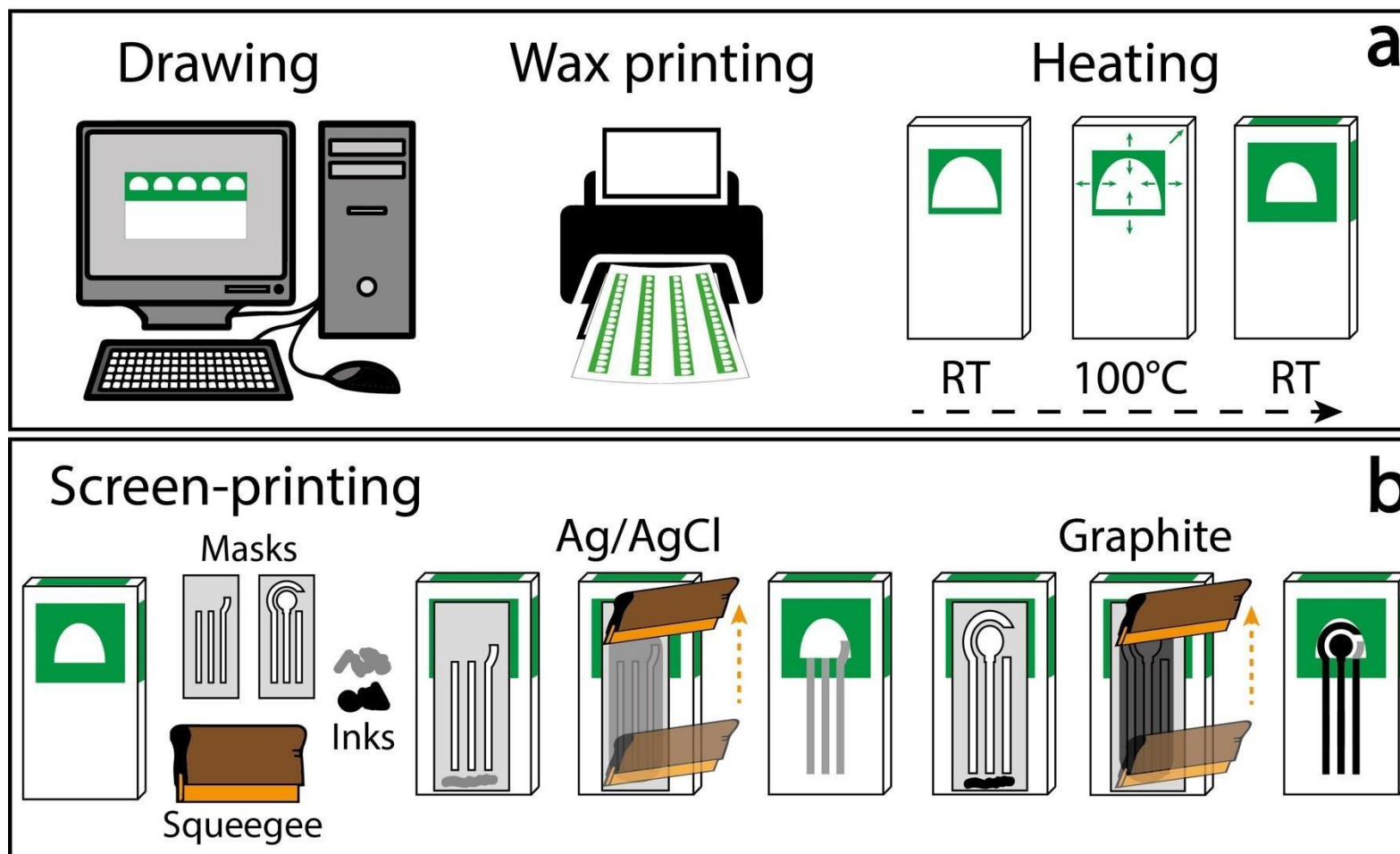

Hydrophilicity matters

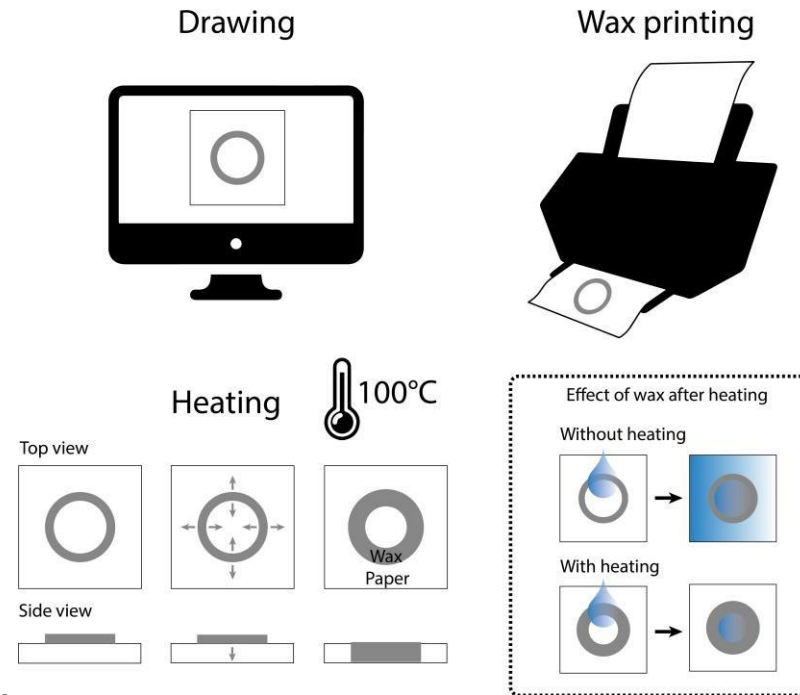

... also the cost!

Costs of the components for producing one device (all the costs have to be intended in Euro).

| Substrate | Ag/AgCl ink | Carbon ink | Insulator | Substrate | Total cost | Saving ^c |
|--------------|-------------|------------|--------------------|-----------|------------|---------------------|
| Polyester | 0.010 | 0.007 | 0.003 ^a | 0.013 | 0.033 | 45% |
| Whatman #1 | | | 0.001 ^b | 0.007 | 0.025 | 30% |
| Office paper | | | 0.001 ^b | 0.0001 | 0.018 | / |

^a Insulator ink.

^b Wax.

^c Calculated as $1 - [\text{Office paper/Other}] \times 100$.

It depends on what you need and you have!

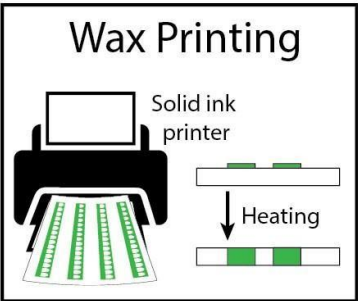

Sustainable
Low resolution

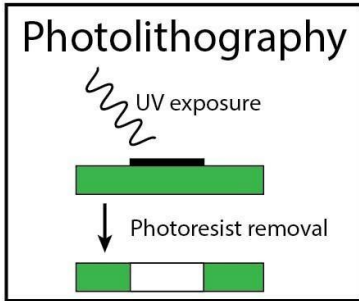

High resolution
Expensive

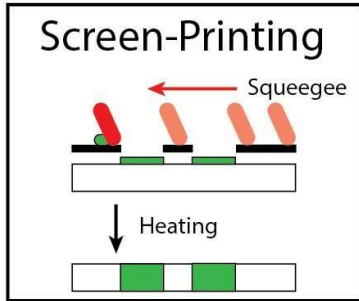

Easiness
Ad hoc masks

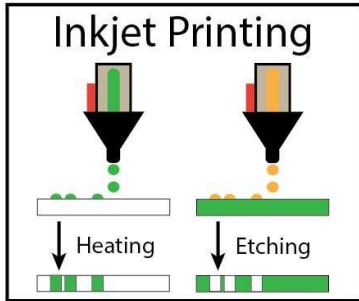

Reduced waste
Expensive printer

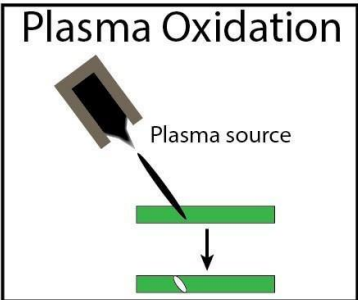

Cheap patterning
Hydrophobized paper

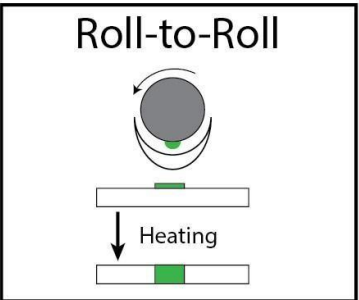

Mass scalable
Too many steps

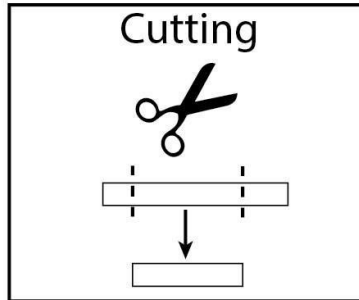

Low-cost
No channels

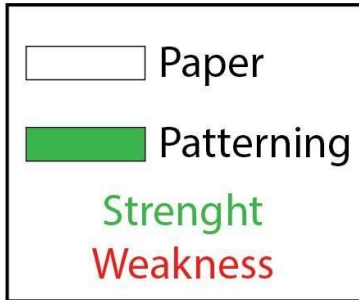

Which E-Paper?

Porous

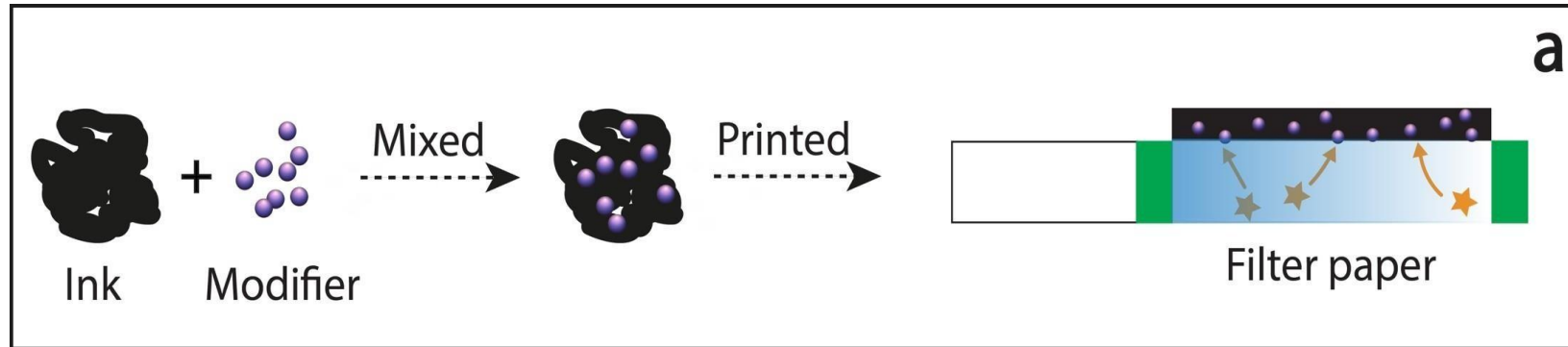

Non porous

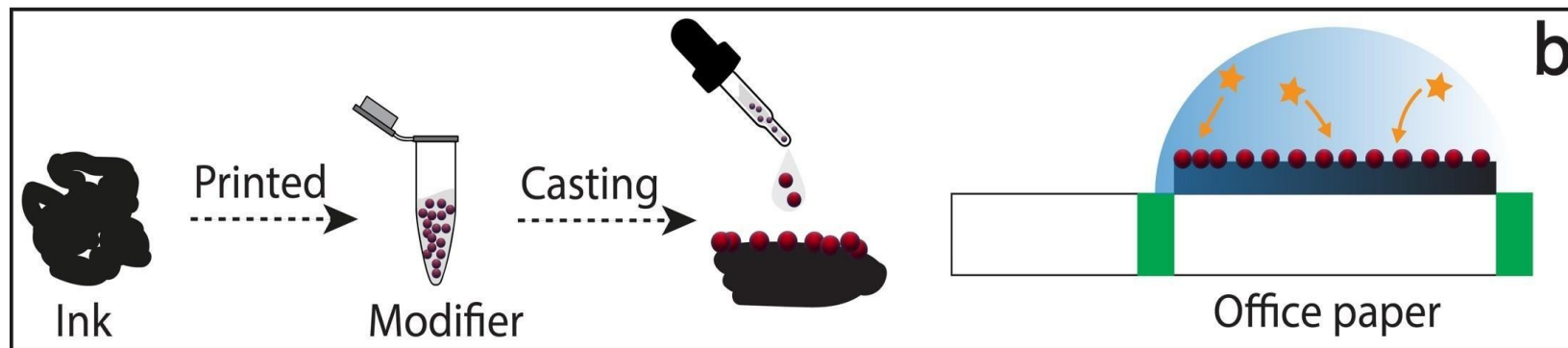

Anyway, paper is the substrate... we need to make these strips ad-hoc

Office paper for ethanol

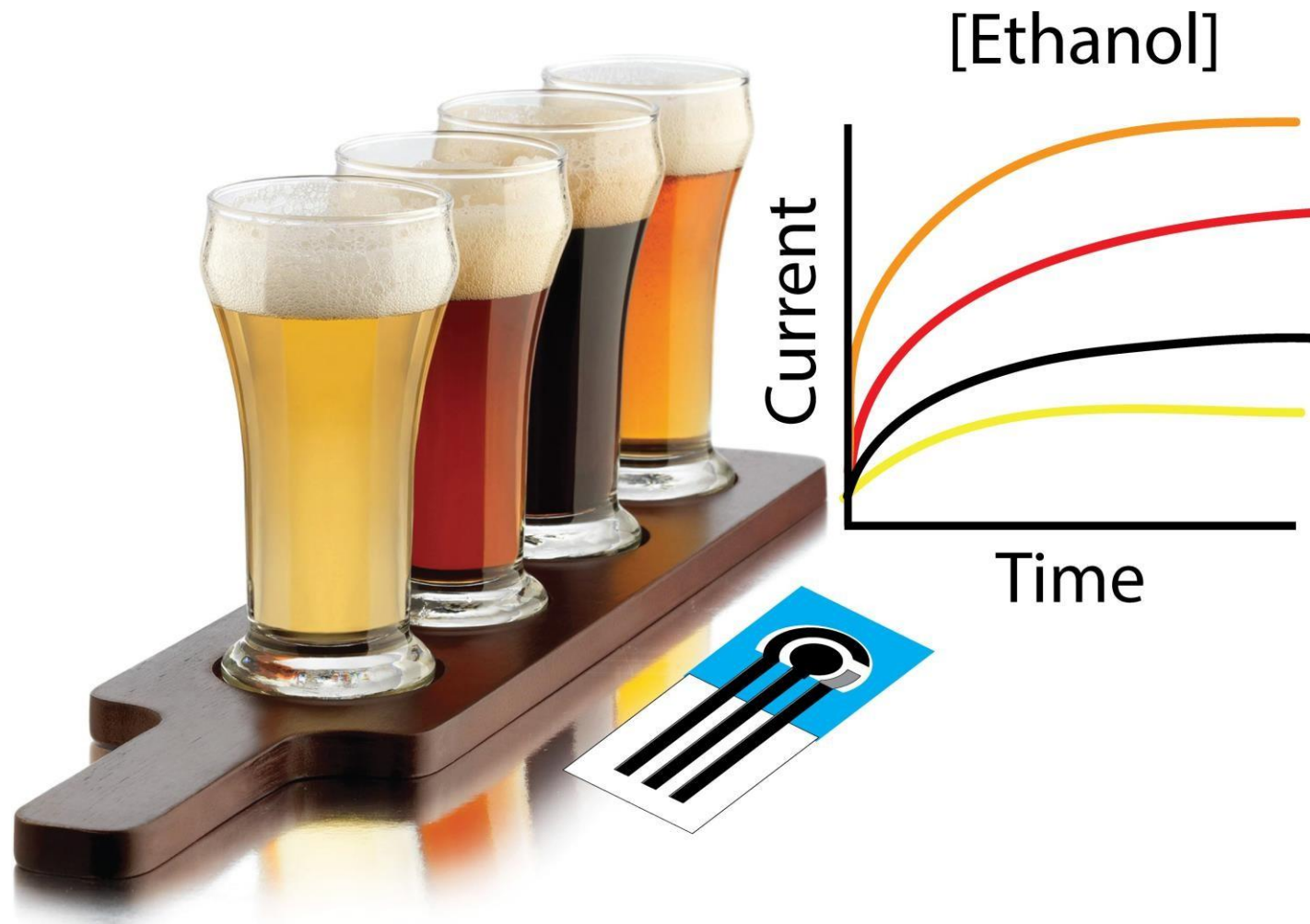

Detection mechanism

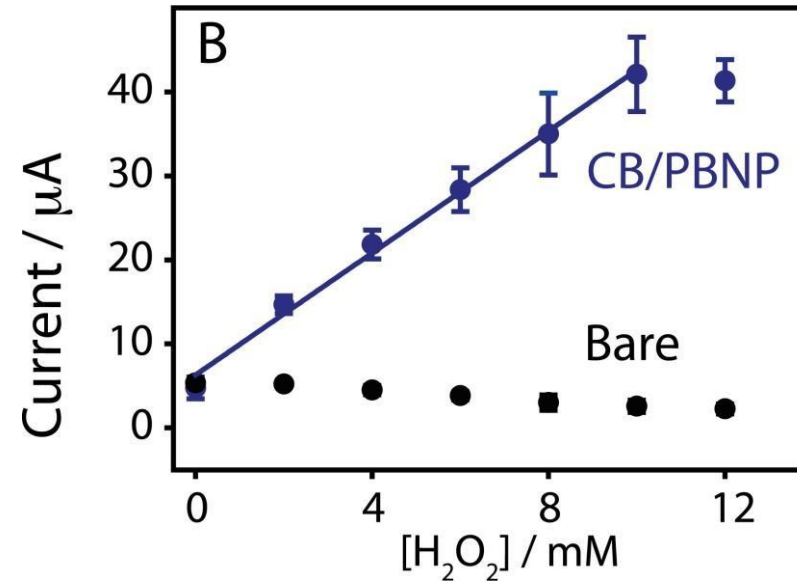
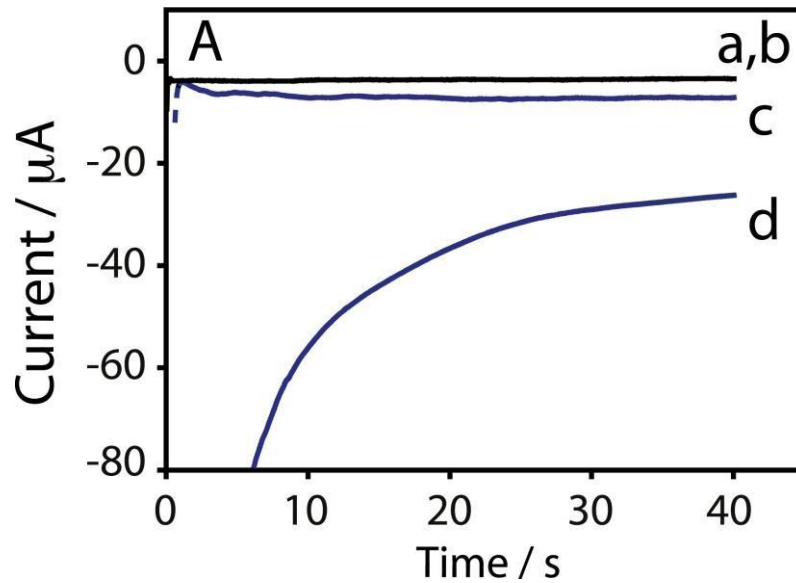
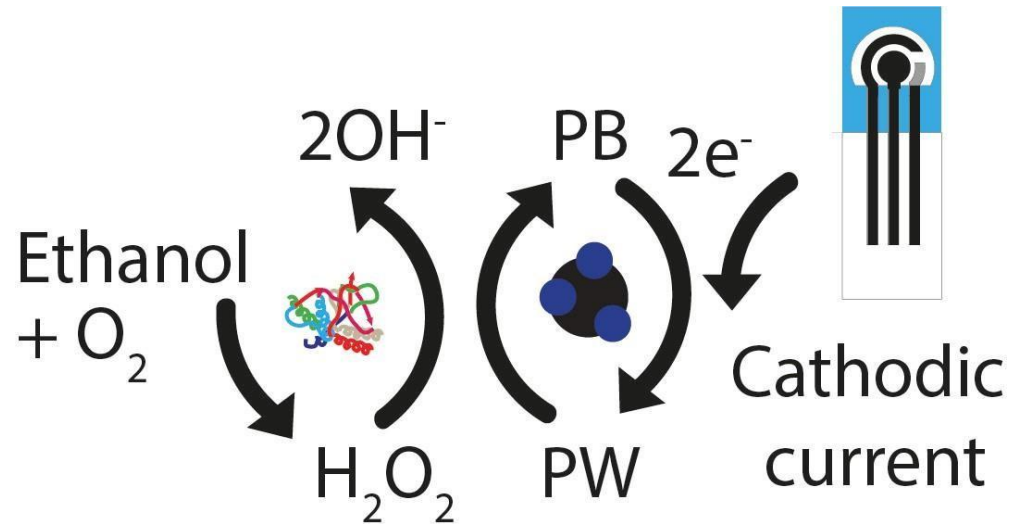

Optimization

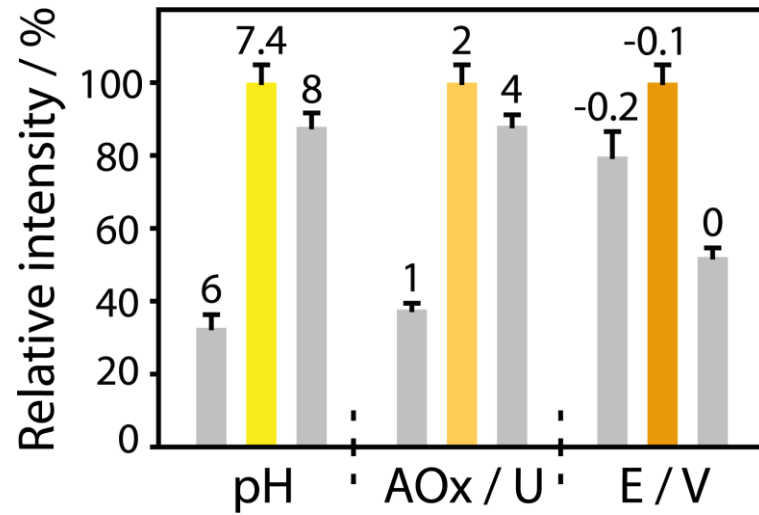

Calibration curve

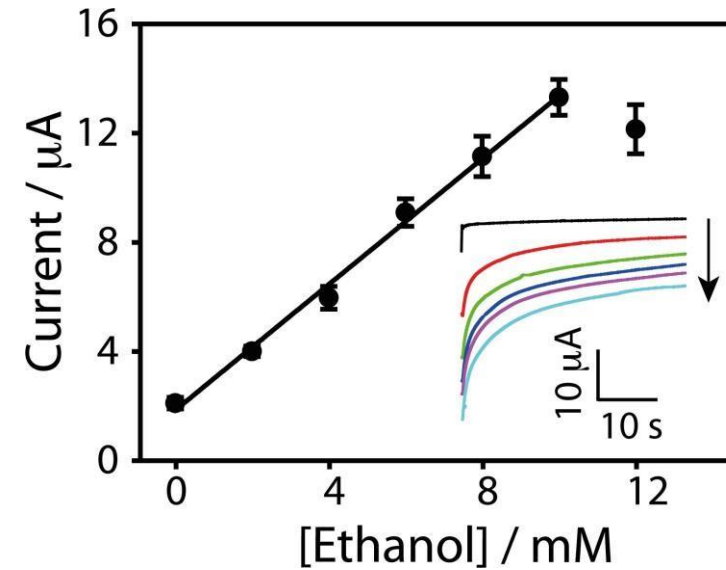

LOD = 0.5 mM

Linear range up to 10 mM

RSD = 8 %

Accordance with label

Detection of ethanol in commercial beers.

| Beer | Lager Best Bräu, Poland | Weiss Franziskaner, Germany | Pilsner Ceres, Denmark | Alcohol free Tourtel, Italy |
|--------------------------|------------------------------|-----------------------------------|------------------------------|-----------------------------------|
| | | | | |
| Label [ethanol]/%vol (M) | 4.7% (0.805 M) | 5% (0.856 M) | 4.6% (0.787 M) | <0.5% (0.086 M) |
| Found [ethanol]/%vol (M) | 4.7 ± 0.4 (0.805 ± 0.075) | 5.0 ± 0.4 (0.86 ± 0.07) | 4.4 ± 0.2 (0.75 ± 0.04) | 0.34 ± 0.03 (0.059 ± 0.004) |
| RSD/% | 9.3 | 8.1 | 5.3 | 6.8 |